

DIO2032X

350 μ A, 6MHz, Rail-to-Rail I/O CMOS Operational Amplifiers

Features

- Supply Voltage Range: 2.5V to 5.5V
- Low Supply Current: 350 μ A Typically
- Rail-to-Rail Input and Output
- 6MHz High Gain-Bandwidth Product
- High Slew Rate: 3.6V/ μ s
- Settling Time to 0.1% with 2V Step: 2.1 μ s
- Overload Recovery Time: 0.9 μ s
- Packages:
- DIO20321 Available in: SOT23-5/SOIC-8
DIO20322 Available in:
SOIC-8/MSOP-8/TSSOP-8
DIO20324 Available in: TSSOP-14/SOIC-14
DIO2036 Available in: QFN4*4-20

Applications

- Audio Output
- Sensor Interface
- Active Filters
- A/D Converters
- Cellular and Cordless Phones
- Laptops and PDAs
- Photodiode Amplification
- Battery-Powered Instrumentation

Ordering Information

Order Part Number	Top Marking		T _A	Package	
DIO20321ST5	YWXH	RoHS/Green	-40 to +125°C	SOT23-5	Tape & Reel, 3000
DIO20321SO8	DIO2031	RoHS/Green	-40 to +125°C	SOIC-8	Tape & Reel, 2500
DIO20322SO8	DIO2032	RoHS/Green	-40 to +125°C	SOIC-8	Tape & Reel, 2500
DIO20322MP8	DIO2032	RoHS/Green	-40 to +125°C	MSOP-8	Tape & Reel, 3000
DIO20322TP8	DIO2032	RoHS/Green	-40 to +125°C	TSSOP-8	Tape & Reel, 3000
DIO20324SO14	DIO2034	RoHS/Green	-40 to +125°C	SOP-14	Tape & Reel, 2500
DIO20324TP14	DIO2034	RoHS/Green	-40 to +125°C	TSSOP-14	Tape & Reel, 2500
DIO2036QN20	DIO2036	RoHS/Green	-40 to +125°C	QFN4*4-20	Tape & Reel, 5000

Descriptions

The DIO20321 (single), DIO20322 (dual) and DIO20324 (quad) and DIO2036 (Triple) are amplifiers with very low noise, low voltage, and low power operational. The DIO20321/2/4/6 has a high gain-bandwidth product of 6MHz, a slew rate of 3.6V/ μ s, and a quiescent current of 350 μ A/amplifier at 5V typically.

The DIO20321/2/4/6 is designed to provide optimal performance in low voltage and low noise systems. All these chips provide rail-to-rail output swing into heavy loads. The input common-mode voltage range includes ground, and the maximum input offset voltage is 3.5mV for DIO20321/2/4/6.

They are specified over the extended industrial temperature range (-40°C to +125°C). The operating range is from 2.5V to 5.5V.

Pin Assignments

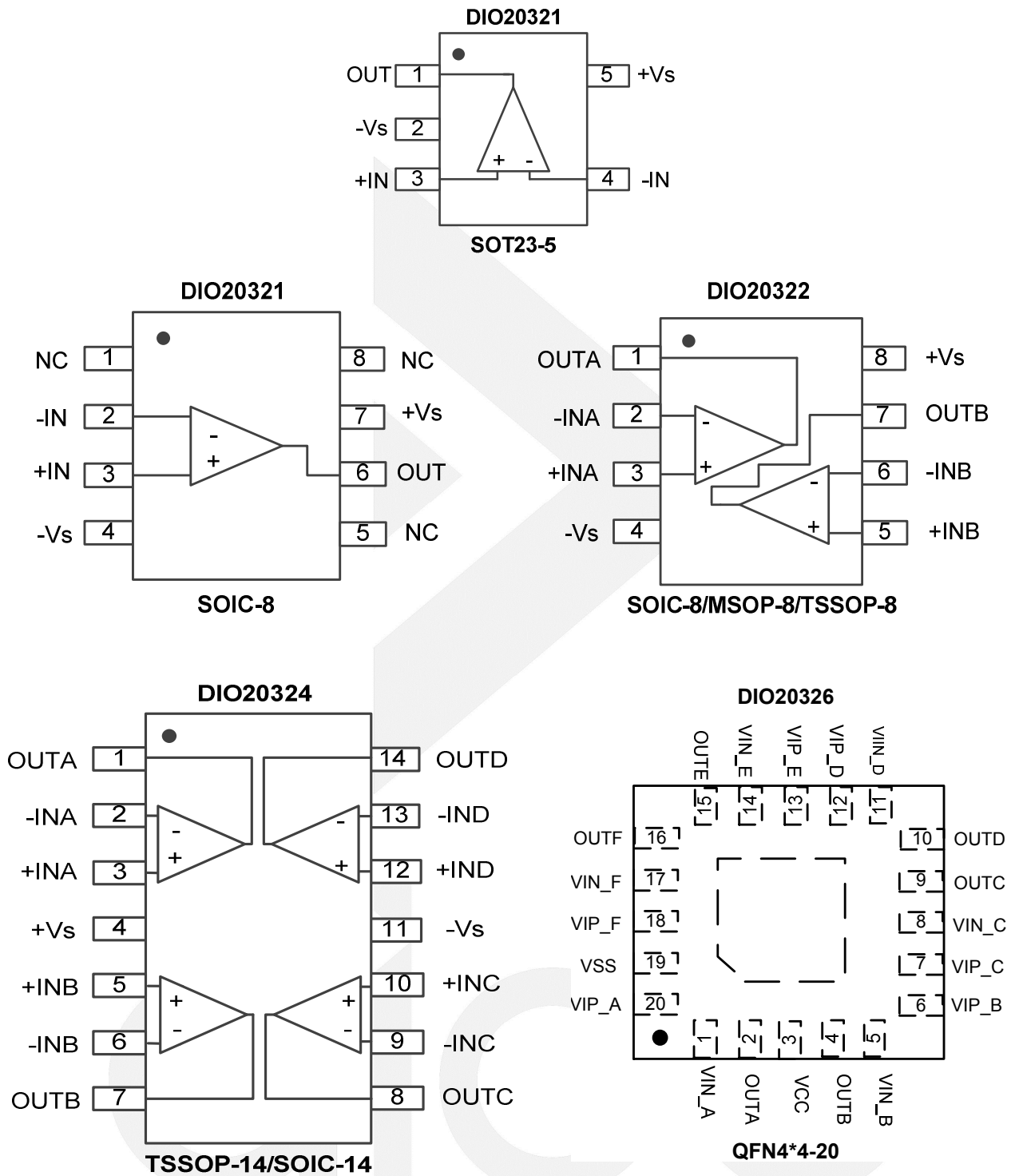

Figure 1 Pin assignment (Top View)

Pin Description

Pin name	Description
+Vs	Positive supply
-Vs	Negative supply
+IN (+INA/+INB/+INC/+IND/+INE/+INF)	Positive Input (channel A/B/C/D/E/F)
-IN (-INA/-INB/-INC/-IND/-INE/-INF)	Negative Input (channel A/B/C/D/E/F)
OUT (OUTA/OUTB/OUTC/OUTD/OUTE/OUTF)	Output (channel A/B/C/D/E/F)
NC	Not Connect

Absolute Maximum Ratings

Stresses beyond those listed under “Absolute Maximum Rating” may cause permanent damage to the device. These are stress ratings only and functional operation of the device at these or any other condition beyond those indicated in the operational sections of the specifications is not implied. Exposure to absolute maximum rating conditions for extended periods may affect device reliability.

Parameter	Rating	Unit
Supply Voltage	7.5	V
Input Voltage	(V-)-0.5 to (V+)+0.5	V
Storage Temperature Range	-65 to 150	°C
Junction Temperature	150	°C
Lead Temperature Range	260	°C
ESD	HBM, JEDEC: JESD22-A114	8
	CDM, JEDEC: JESD22-C101	2

Recommended Operating Conditions

The Recommended Operating Conditions table defines the conditions for actual device operation to ensure optimal performance to the datasheet specifications. DIOO does not recommend exceeding them or designing to Absolute Maximum Ratings.

Parameter	Rating	Unit
Supply Voltage	2.5 to 5.5	V
Input Voltage	0 to 5	V
Operating Temperature Range	-40 to 125	°C

Electrical Characteristics

Typical value: $V_+=5V$, $R_L=100k\Omega$ to $V_+/2$, $T_A = 25^\circ C$, unless otherwise specified.

Symbol	Parameter	Conditions	Min.	Typ.	Max.	Unit
INPUT CHARACTERISTICS						
V_{OS}	Input Offset Voltage	$T_A=25^\circ C$	-3.5	0.7	3.5	mV
I_B	Input Bias Current	$-40^\circ C \leq T_A \leq 125^\circ C$, $V_+=2.5V$ to $5.5V$		1	10	pA
I_{OS}	Input Offset Current	$-40^\circ C \leq T_A \leq 125^\circ C$, $V_+=2.5V$ to $5.5V$		1	10	pA
V_{CM}	Common Mode Voltage Range	$V_+=5.5V$	-0.1		5.6	V
$CMRR$	Common Mode Rejection Ratio	$-40^\circ C \leq T_A \leq 125^\circ C$, $V_S = 5.5V$, $V_{CM}=-0.1V$ to $4V$	75	90		dB
		$-40^\circ C \leq T_A \leq 125^\circ C$, $V_S=5.5V$, $V_{CM}=-0.1V$ to $5.6V$	66	90		dB
A_{OL}	Open Loop Voltage Gain	$R_L=600\Omega$, $V_O=0.15V$ to $4.85V$	92	100		dB
		$R_L=10K\Omega$, $V_O=0.05V$ to $4.95V$	100	110		dB
$\Delta V_{OS}/\Delta T$	Input Offset Voltage Drift	$-40^\circ C \leq T_A \leq 125^\circ C$		2.7		$\mu V/^\circ C$
OUTPUT CHARACTERISTICS						
	Output Voltage Swing from Rail	$R_L=600\Omega$ $-40^\circ C \leq T_A \leq 125^\circ C$			0.1	V
		$R_L=10k\Omega$ $-40^\circ C \leq T_A \leq 125^\circ C$			0.015	
I_{OUT}	Output Current	$V_+=5V$	45	48		mA
R_o	Closed Loop Output Impedance	$F=100kHz$, $G=+1$		2.6		Ω
POWER SUPPLY						
	Operating Voltage Range		2.5		5.5	V
PSRR	Power Supply Rejection Ration		70	94		dB
I_S	Supply Current per Channel/Amp	$V_+=5V$, $-40^\circ C \leq T_A \leq 125^\circ C$		350		μA
		$V_+=2.5V$, $-40^\circ C \leq T_A \leq 125^\circ C$		320		
DYNAMIC PERFORMANCE						
GBP	Gain Bandwidth Product	$R_L=10k\Omega$		6		MHz
SR	Slew Rate	$R_L=600\Omega$, $G=1$, 2V Output Step		3.6		V/ μs
t_s	Setting Time	$R_L=600\Omega$, $G=1$, 2V Output Step			1	μs
NOISE PERFORMANCE						
THD	Total Harmonic Distortion	$f=10kHz$, 1V Output Step, $R_L=600\Omega$ and $100pF$		0.015		%
e_n	Voltage Noise Density	$f=1kHz$, $V_+=5V$		20		nV/ \sqrt{Hz}
		$f=10kHz$, $V_+=5V$		12		

Specifications subject to change without notice.

Typical Application

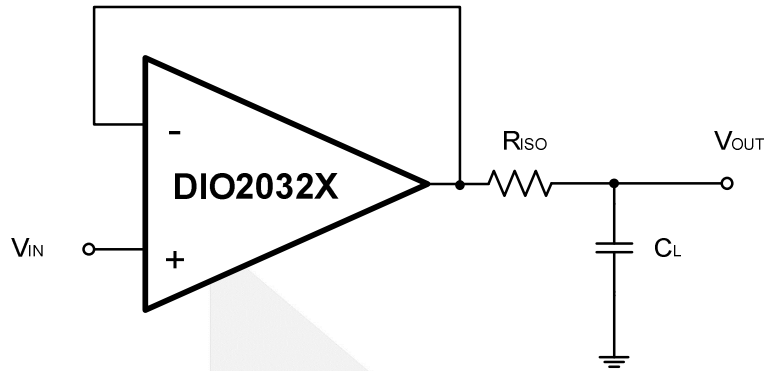

Figure 2 Indirectly Driving Heavy Capacitive Load

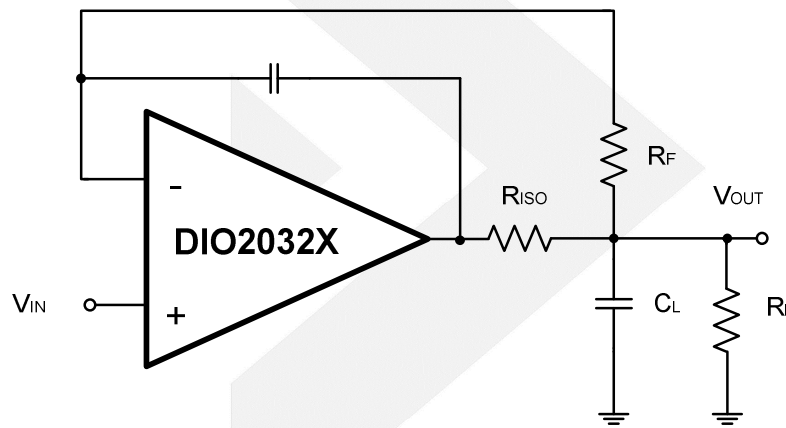

Figure 3 Indirectly Driving Heavy Capacitive Load with DC Accuracy

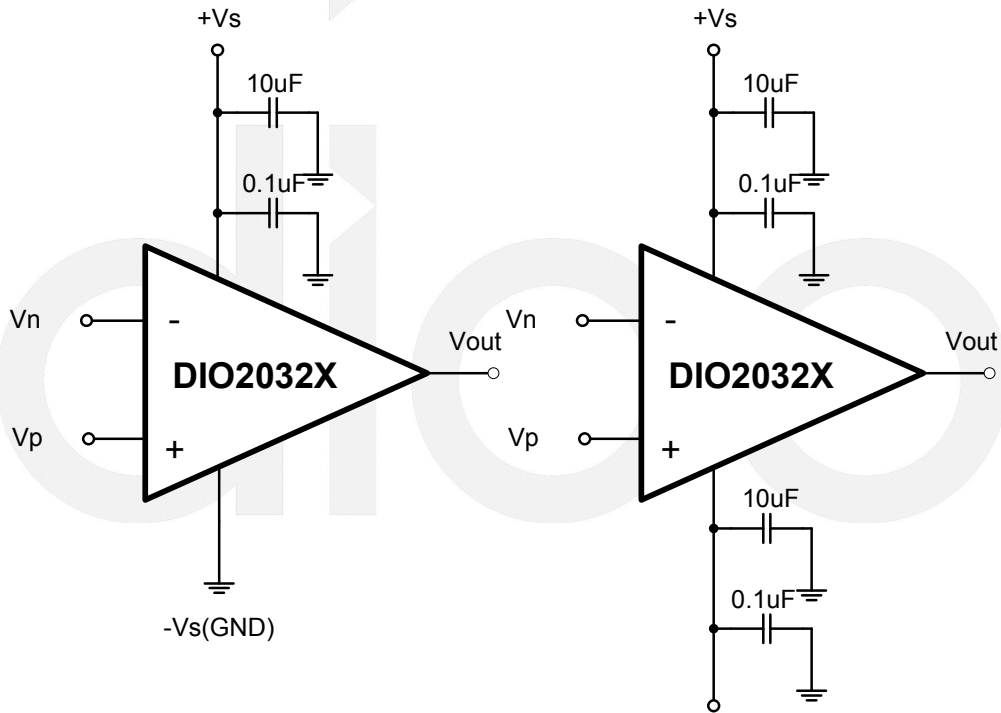
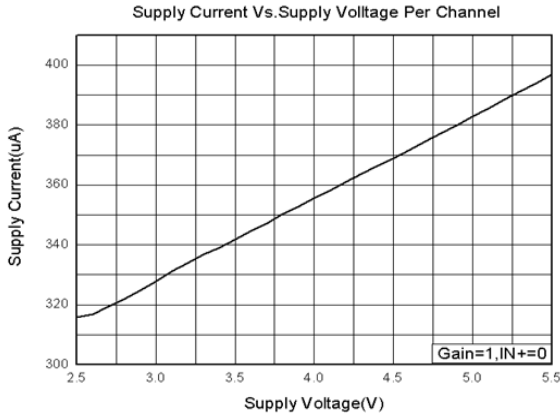

Figure 4 Amplifier with Bypass Capacitors

Typical Performance Characteristics

Typical value: $V_+=5V$, $R_L=100k\Omega$ to $V_+/2$, $T_A = 25^\circ C$, unless otherwise specified.

Supply Current vs. Supply Voltage Per Channel



Supply Current vs. Temperature

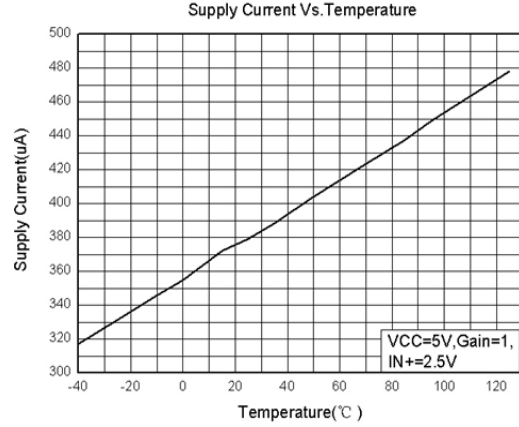

ISOURCE vs. Output Voltage

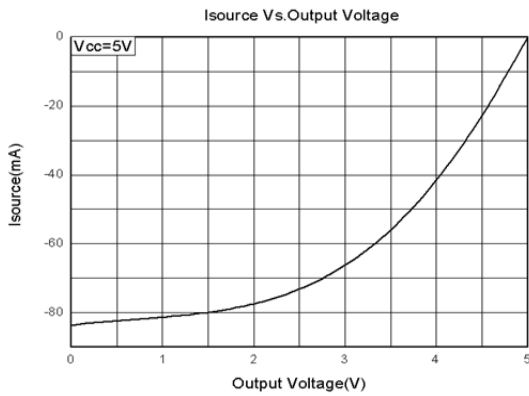

ISINK vs. Output Voltage

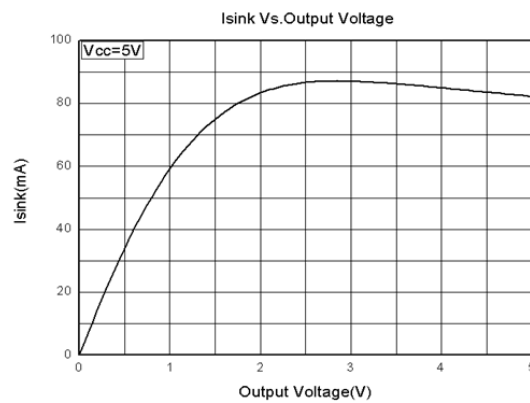

Gain vs. Frequency

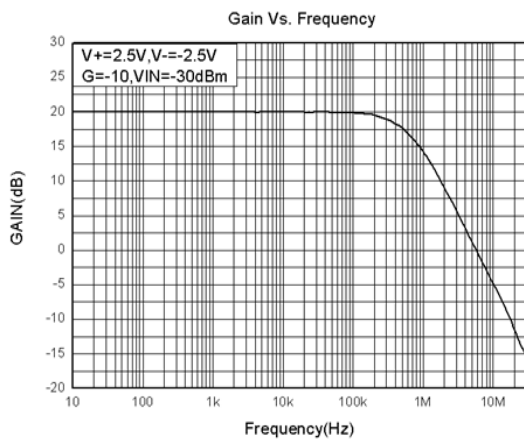

Input Offset Voltage vs. Temperature

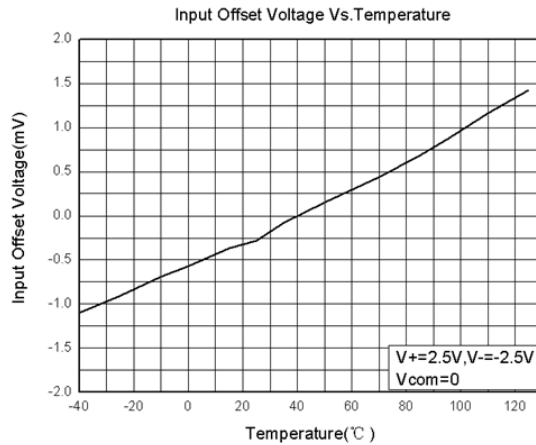

Input Offset Voltage vs. Supply Voltage

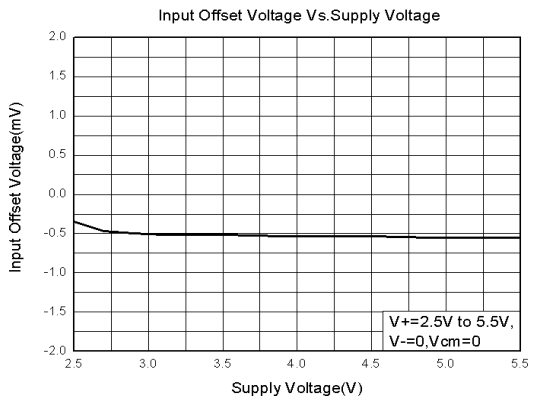

Input Offset Voltage vs. Common Voltage

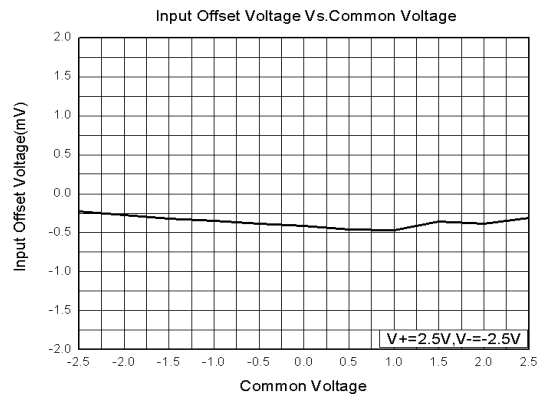

CONTACT US

Dioo is a professional design and sales corporation for high-quality and performance analog semiconductors. The company focuses on industry markets, such as, cell phone, handheld products, laptop, and medical equipment and so on. Dioo's product families include analog signal processing and amplifying, LED drivers and charger IC. Go to <http://www.dioo.com> for a complete list of Dioo product families.

For additional product information, or full datasheet, please contact with our Sales Department or Representatives.

