



## DIO59121A/B/C/D

# USB-Compliant Single-cell Li-Ion 2A Switching Charger

### Features

- Fully Integrated, High-Efficiency Charger for Single-Cell Li-Ion and Li-Polymer Battery Packs
- Faster Charging than Linear
- Charge Voltage Accuracy:  $\pm 0.5\%$  (A:4.2V,B:4.3V,C:4.35V,D:4.4V)
- $\pm 6\%$  Input Current Regulation Accuracy
- $\pm 4\%$  Charge Current Regulation Accuracy
- 26V Absolute Maximum Input Voltage
- 6V Maximum Input Operating Voltage
- 2A Charge Rate
- 1.5MHz Synchronous Buck PWM Controller with Wide Duty Cycle Range
- Small Footprint 1 $\mu$ H External Inductor
- Dynamic Input Voltage Control
- Low Reverse Leakage to Prevent Battery Drain to VBUS
- Available in DFN3\*3-12 Package.

### Descriptions

The DIO59121X is a highly integrated switch-mode charger, to minimize single-cell Lithium-ion (Li-ion) charging time from a USB power source.

The charger regulator circuits switch at 1.5M Hz to minimize the size of external passive components.

The DIO59121X provides battery charging in three phases: pre-charge, constant current and constant voltage.

To ensure USB compliance, the input current limit can be set at 500mA.

The integrated circuit (IC) automatically restarts the charge cycle when the battery falls below an internal threshold. If the input source is removed, the IC enters a high-impedance mode, preventing leakage from the battery to the input. Charge current is reduced when the die temperature reaches at 120°C, protecting the device and PCB from damage.

### Applications

- Cell Phones, Smart Phones, PDAs
- Tablet, Portable Media Players
- Gaming Device, Digital Cameras

### Ordering Information

Order Part Number	Top Marking		T <sub>A</sub>	Package	
DIO59121XCD12	59121X	Green	-40 to 85°C	DFN3*3-12	Tape & Reel, 5000

## Pin Assignments

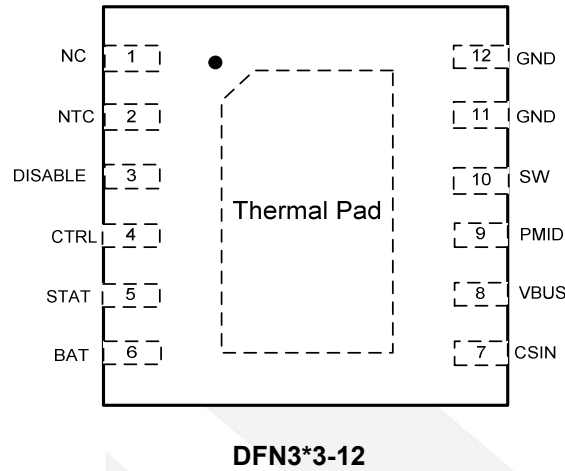

Figure 1. Pin Assignment (Top View)

## Pin Definitions

Name	Description
NC	No Connect. Suggest shorting to GND.
NTC	Monitor battery temperature input connected to the battery NTC resistor (10kΩ).
DISABLE	Charging enable input, charging start when disable is low.
CTRL	CTRL=0, input current limit is 500mA. CTRL=1, input current is no limit.
STAT	Status. Open-drain output indicating charge status. The IC pulls this pin LOW when charging, and pulses STAT pin when fault.
BAT	Battery Voltage. Connect to the positive (+) terminal of the battery pack. Bypass with a 0.1μF capacitor to GND if the battery is connected through long leads.
CSIN	Charging current detection input terminal.
VBUS	Charger Input Voltage. Bypass with a 1μF capacitor to PGND.
PMID	Power Input Voltage. Power input to the charger regulator, bypass point for the input current sense, and high-voltage input switch. Bypass with a minimum of 10μF, 6.3V capacitor to PGND.
SW	Switching Node. Connect to output inductor.
GND	Ground.
Thermal Pad	Exposed pad beneath the IC for heat dissipation. Always solder thermal pad to the board, and have via on the thermal pad plane star-connecting to GND.



# DIO59121X

USB-Compliant Single-Cell Li-Ion 2A Switching Charger

## Absolute Maximum Ratings

Stresses beyond those listed under “Absolute Maximum Rating” may cause permanent damage to the device. These are stress ratings only and functional operation of the device at these or any other condition beyond those indicated in the operational sections of the specifications is not implied. Exposure to absolute maximum rating conditions for extended periods may affect device reliability.

Parameter		Rating	Unit
VBUS Voltage	Continuous	-1.4 to 26.0	V
	Pulsed, 100ms Maximum Non-Repetitive	-2.0 to 26.0	
STAT Voltage		-0.3 to 26.0	V
PMID Voltage		6.5	V
SW, CSIN, VBAT, DISABLE Voltage		-0.3 to 6.5	
Voltage on Other Pins		-0.3 to 6.5	V
Maximum V <sub>BUS</sub> Slope above 5.5V when Charger are Active		4	V/ $\mu$ s
ESD	HBM	2000	V
	CDM	500	
Junction Temperature		-40 to 150	$^{\circ}$ C
Storage Temperature		-65 to 150	$^{\circ}$ C
Lead Soldering Temperature, 10 Seconds		260	$^{\circ}$ C

## Recommend Operating Conditions

The Recommended Operating Conditions table defines the conditions for actual device operation. Recommended Operating conditions are specified to ensure optimal performance to the datasheet specifications. DIOO does not Recommend exceeding them or designing to Absolute Maximum Ratings.

Parameter		Rating	Unit
Supply Voltage		4 to 6	V
Negative VBUS Slew Rate during VBUS Short Circuit, C <sub>MID</sub> $\leq$ 4.7 $\mu$ F	T <sub>A</sub> $\leq$ 60 $^{\circ}$ C	4	V/ $\mu$ s
	T <sub>A</sub> $\geq$ 60 $^{\circ}$ C	2	
Ambient Temperature		-30 to 85	$^{\circ}$ C
Junction Temperature		-30 to 120	$^{\circ}$ C



# DIO59121X

USB-Compliant Single-Cell Li-Ion 2A Switching Charger

## Electrical Characteristics

$V_{IN} = 5V$ ,  $T_A = 25^{\circ}C$ , unless otherwise specified.

Symbol	Parameter	Test Conditions	Min	Typ	Max	Unit
<b>Power Supplies</b>						
$I_{VBUS}$	VBUS Current	$V_{BUS} > V_{BUS(min)}$ , PWM Switching		10		mA
		$V_{BUS} > V_{BUS(min)}$ ; PWM Enabled, Not Switching		0.2		mA
		DISABLE=1		96		$\mu A$
$I_{LKG}$	VBAT to VBUS Leakage Current <sup>(1)</sup>	$0^{\circ}C < T_J < 85^{\circ}C$ , $V_{BAT}=4.2V$ , $V_{BUS}=0V$		1.6	5.0	$\mu A$
$I_{BAT}$	Battery is charge Current in High-Impedance Mode	DISABLE=1, $0^{\circ}C < T_J < 85^{\circ}C$ , $V_{BAT}=4.2V$		12	20	$\mu A$
<b>Charger Voltage Regulation</b>						
$V_{OREG}$	Charge Voltage Range		4.2		4.4	V
	Charge Voltage Accuracy	$T_A=25^{\circ}C$	-0.5%		0.5%	
		$T_J=0$ to $125^{\circ}C$	-1%		1%	
<b>Charging Current Regulation</b>						
$I_{OCHRG}$	Output Charge Current Range	$I_{OCHRG} = 101.9mV / R_{SENSE}$ $R_{SENSE}=51m\Omega$		2		A
	Charge Current Accuracy Across $R_{SENSE}$		-4		4	%
<b>Logic Levels: DISABLE</b>						
$V_{IH}$	High-Level Input Voltage		1.05			V
$V_{IL}$	Low-Level Input Voltage				0.4	V
$I_{IN}$	Input Bias Current	Input=5V		5.0		$\mu A$
<b>Charge Termination Detection</b>						
$I_{(TERM)}$	Termination Current Range	$I_{(TERM)} = 9.38mV / R_{SENSE}$		184		mA
	Termination Current Accuracy	$R_{SENSE}=51m\Omega$	-3		3	%
	Termination Current Deglitch Time			30		ms
<b>Input Power Source Detection</b>						
$V_{IN(MIN)}$	VBUS Input Voltage Rising	To Initiate and Pass VBUS Validation	3.75	4	4.25	V
$V_{hys}$				0.3		V
$t_{VBUS\_VALID}$	VBUS Validation Time			30		ms
<b>Special Charger (<math>V_{BUS}</math>)</b>						



# DIO59121X

USB-Compliant Single-Cell Li-Ion 2A Switching Charger

V <sub>SP</sub>	Special Charger VBUS Voltage			4.5		V
	Special Charger Set point Accuracy		-4		4	%
<b>Input Current Limit</b>						
I <sub>INLIM</sub>	Input Current Limit Threshold	CTRL=0	470	500	530	mA
		CTRL=1		No limit		
<b>Battery Recharge Threshold</b>						
V <sub>RCH</sub>	Recharge Threshold	Below V <sub>(OREG)</sub>	70	100	130	mV
	Deglintch Time	V <sub>BAT</sub> Falling Below V <sub>RCH</sub> Threshold		30		ms
<b>STAT Output</b>						
V <sub>STAT(OL)</sub>	STAT Output Low	I <sub>STAT</sub> =10mA			0.4	V
I <sub>STAT(OH)</sub>	STAT High Leakage Current	V <sub>STAT</sub> =5V			1	μA
<b>Sleep Comparator</b>						
V <sub>SLP</sub>	Sleep-Mode Entry Threshold, V <sub>BUS</sub> - V <sub>BAT</sub>	$4V \leq V_{BAT} \leq V_{OREG}$ , V <sub>BUS</sub> Falling	0	0.04	0.1	V
V <sub>SLP-EXIT</sub>	Sleep-Mode Exit Threshold, V <sub>BUS</sub> - V <sub>BAT</sub>			0.1		V
t <sub>SLP_EXIT</sub>	Deglintch Time for VBUS Rising Above V <sub>BAT</sub> by V <sub>SLP</sub>	Rising Voltage		30		ms
<b>Power Switches</b>						
R <sub>DS(ON)</sub>	Q3 On Resistance(VBUS to PMID)	I <sub>IN(LIMIT)</sub> =500mA		86		mΩ
	Q1 On Resistance(PMID to SW)			85		
	Q2 On Resistance(SW to GND)			75		
<b>Charger PWM Modulator</b>						
f <sub>SW</sub>	Oscillator Frequency			1.5		MHz
D <sub>MAX</sub>	Maximum Duty Cycle				100	%
D <sub>MIN</sub>	Minimum Duty Cycle			6		%
I <sub>SYNC</sub>	Synchronous to Non-Synchronous Current Cut-Off Threshold	Low-Side MOSFET(Q2) Cycle-by-Cycle Current Limit		300		mA
<b>Battery Detection</b>						
I <sub>DETECT</sub>	Battery Detection Sink Current	Begins after Charge Termination Detected		10		mA
t <sub>DETECT</sub>	Battery Detection Time			30		ms
<b>Protection and Timers</b>						
VBUS <sub>OV</sub> P	VBUS Over-Voltage Shutdown	V <sub>BUS</sub> Rising	5.82	6	6.2	V



# DIO59121X

	Hysteresis	V <sub>BUS</sub> Falling		200		mV
I <sub>LIMPK(CHG)</sub>	Q1 Cycle-by-Cycle Peak Current Limit	Charge Mode		3.4		A
V <sub>SHORT</sub>	Battery Short-Circuit Threshold	V <sub>BAT</sub> Rising	1.95	2	2.05	V
	Hysteresis	V <sub>BAT</sub> Falling		100		mV
I <sub>SHORT</sub>	Linear Charging Current	V <sub>BAT</sub> <V <sub>SHORT</sub>	20	30	40	mA
T <sub>SHUTDOWN</sub>	Thermal Shutdown Threshold	T <sub>J</sub> Rising		145		°C
	Hysteresis	T <sub>J</sub> Falling		10		
T <sub>CF</sub>	Thermal Regulation Threshold	Charge Current Reduction Begins		120		°C
t <sub>INT</sub>	Detection Interval			30		ms
<b>NTC</b>						
T <sub>DET_RANGE</sub>	Detected temperature range	R <sub>NTC</sub> =10 KΩ	0		50	°C
V <sub>NTC_HOT</sub>	High temperature detection voltage threshold	Battery temperature rise		0.12		V
	High temperature detection voltage hysteresis	Battery temperature drop		40		mV
V <sub>NTC_COLD</sub>	Low temperature detection voltage threshold	Battery temperature drop		0.9		V
	Low temperature detection voltage hysteresis	Battery temperature rise		60		mV

Note (1): Guarantee by design.



## Block Diagram

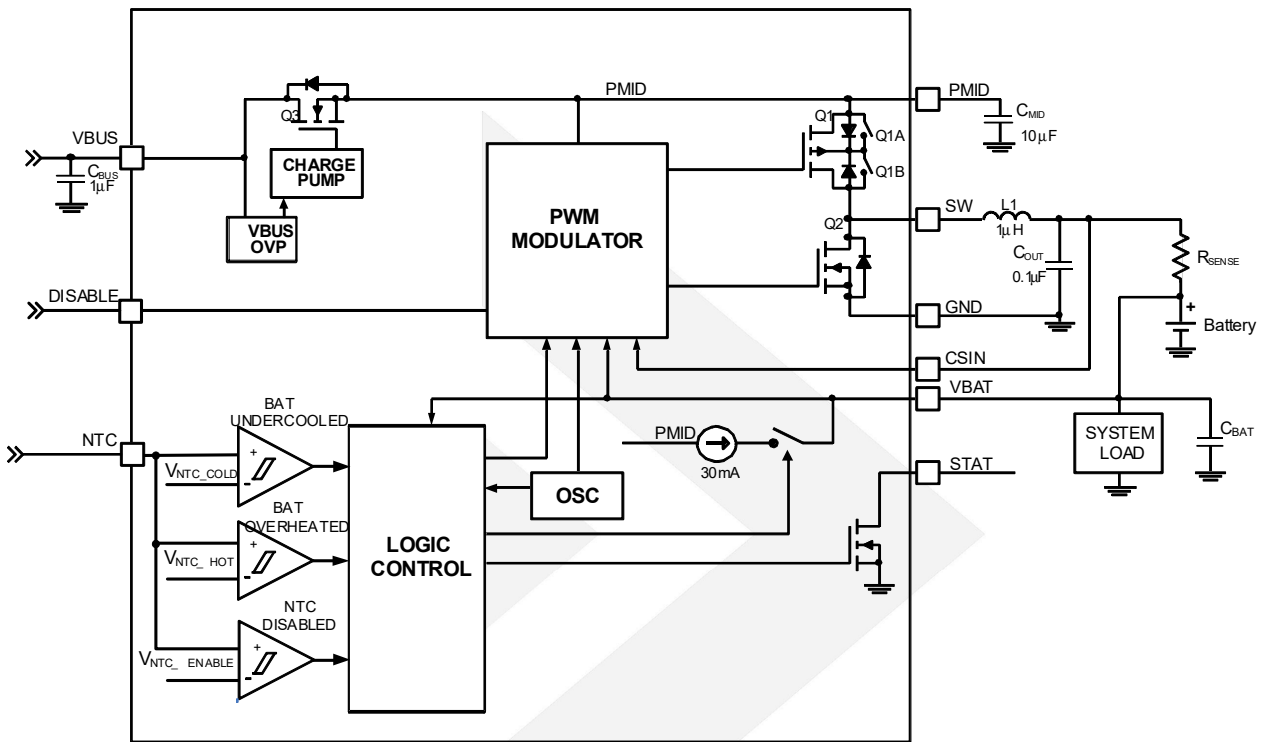

Figure 2. IC and System Block Diagram

## Typical Application

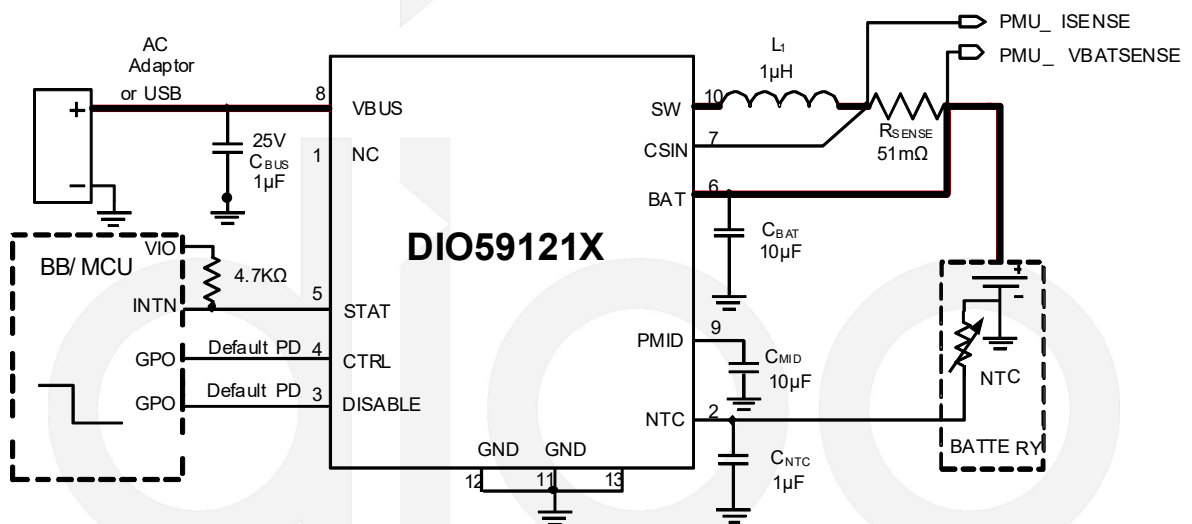

Figure 3. Typical Application

## Application Information

### Circuit Description/Overview

When charging batteries with a current-limited input source, such as USB, a switching charger's high efficiency over a wide range of output voltages minimizes charging time.

DIO59121X has a highly integrated synchronous buck regulator for charging. The regulator employs synchronous rectification to maintain high efficiency over a wide range of battery voltages and charge states.

The DIO59121X has two operating modes:

1. **Charge Mode:**  
Charge a signal-cell Li-ion or Li-polymer battery.
2. **High-Impedance Mode:**  
Charging circuits are OFF in this mode. Current flow from VBUS to the battery or from the battery to VBUS is blocked in this mode. This mode consumes very little current from VBUS or the battery.

### Charge Mode

In charge Mode, DIO59121X employs four regulation loops:

1. **Input Current:** Limits the amount of current drawn from VBUS. This current is sensed internally and can be set by CTRL pin.
2. **Charging Current:** Limits the maximum charging current. This current is sensed using an external  $R_{SENSE}$  resistor.
3. **Charge Voltage:** The regulator is restricted from exceeding this voltage. As the internal battery voltage rises, the battery's internal impedance and  $R_{SENSE}$  work in conjunction with the charge voltage regulation to decrease the amount of current flowing to the battery. Battery charging is completed when the voltage across  $R_{SENSE}$  drops below the  $I_{TERM}$  threshold.
4. **Temperature:** If the IC's junction temperature reaches  $120^{\circ}\text{C}$ , charge current is reduced until the IC's temperature stabilizes at  $120^{\circ}\text{C}$ .
5. An additional loop limits the amount of drop on VBUS to a voltage ( $V_{SP}$ ) to accommodate "special chargers" that limit current to a lower current than might be available from a "normal" USB wall charger.

### Battery Charging Curve

If the battery voltage is below  $V_{SHORT}$ , a linear current source pre-charges the battery until  $V_{BAT}$  reaches  $V_{SHORT}$ . The PWM charging circuit is then started and the battery is charged with a constant current if sufficient input power is available. The current slew rate is limited to prevent overshoot.

The DIO59121X is designed to work with a current-limited input source at VBUS. During the current regulation phase of charging,  $I_{INLIM}$  limits the current available to charge the battery and power the system. The effect of  $I_{INLIM}$  on  $I_{CHARGE}$  can be seen in Figure 5.



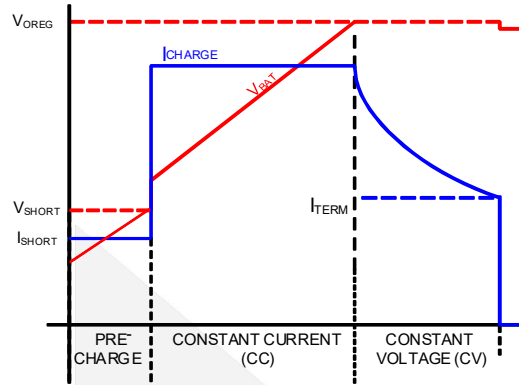

**Figure 4. Charge Curve,  $I_{CHARGE}$  Not Limited by  $I_{INLIM}$**

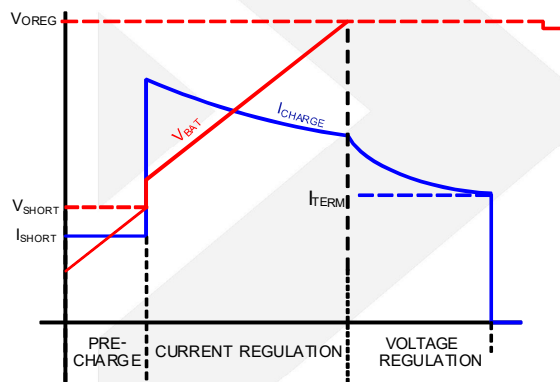

**Figure 5. Charge Curve,  $I_{INLIM}$  Limits  $I_{CHARGE}$**

Assuming that  $V_{OREG}$  is programmed to the cell's fully charged "float" voltage, the current that the battery accepts with the PWM regulator limiting its output (sensed at  $V_{BAT}$ ) to  $V_{OREG}$  declines, and the charger enters the voltage regulation phase of charging. When the current declines to  $I_{TERM}$  value, the charge cycle is complete.

A new charge cycle begins when one of the following occurs:

- The battery voltage falls below  $V_{OREG} - V_{RCH}$
- $V_{BUS}$  Power on Reset (POR) clears and the battery voltage is below the  $V_{SHORT}$ .
- Reset DISABLE pin.

### PWM Controller in Charge Mode

The IC uses a current-mode PWM controller to regulator the output voltage and battery charge currents. The synchronous rectifier (Q2) has a current limit that which off the FET when the current is negative by more than 400mA peak. This prevents current flow from battery.

### $V_{BUS}$ POR/Non-Compliant Charger Rejection

When the IC detects that  $V_{BUS}$  has risen above  $V_{IN(MIN)}$  (4.3V), the IC applies a  $250\Omega$  load from  $V_{BUS}$  to GND. To clear the  $V_{BUS}$  POR (Power-On-Reset) and begin charging,  $V_{BUS}$  must remain above  $V_{IN(MIN)}$  and below  $V_{BUS_{OVP}}$  for  $t_{VBUS\_VALID}$  (30ms) before the IC initiates Charging. The  $V_{BUS}$  validation sequence always occurs charging is initiated or re-initiated (for example, after a  $V_{BUS}$  OVP fault or a  $V_{RCH}$  recharge initiation).

$t_{VBUS\_VALID}$  ensures that unfiltered 50/60Hz chargers and other non-compliant chargers are rejected.

### Special Charger

The DIO59121X has additional functionality to limit input current in case a current-limited “special charger” is supplying V<sub>BUS</sub>. These slowly increase the charging current until either.

- $I_{INLIM}$  or  $I_{OCHARGE}$  is reached

or

- $V_{BUS} = V_{SP}$ .

If V<sub>BUS</sub> collapses to V<sub>SP</sub> when the current is ramping up, the DIO59121X charge with an input current that keeps V<sub>BUS</sub> = V<sub>SP</sub>.

### Thermal Regulation and Protection

When the IC's junction temperature reaches T<sub>CF</sub> (about 120°C), the charger reduces its output current to prevent overheating. If the temperature increases beyond T<sub>SHUTDOWN</sub>; charging is suspended, and STAT is pulsed. Charging resumes after the die cools to about 120°C.

### Charge Mode Input Supply Protection

#### Sleep Mode

When V<sub>BUS</sub> falls below V<sub>BAT</sub> + V<sub>SLP</sub> and V<sub>BUS</sub> is above V<sub>IN(MIN)</sub>, the IC enters Sleep Mode to prevent the battery from draining into V<sub>BUS</sub>. During Sleep Mode, reverse current is disabled by body switching Q1.

### Input Supply Low-Voltage Detection

The IC continuously monitors V<sub>BUS</sub> during charging. If V<sub>BUS</sub> falls below V<sub>IN(MIN)</sub>, the IC:

1. Terminates charging.
2. Pulses the STAT pin.

If V<sub>BUS</sub> recovers above the V<sub>IN(MIN)</sub> rising threshold after time 30ms, the charging process is repeated. This function prevents the USB power bus from collapsing or oscillating when the IC is connected to a suspended USB port or a low-current-capable OTG device.

### Input Over-Voltage Detection

When the V<sub>BUS</sub> exceeds V<sub>BUS\_OVP</sub>, the IC:

1. Turns off Q3
2. Suspends charging
3. Pulses the STAT pin.

When V<sub>BUS</sub> falls about 200mV below V<sub>BUS\_OVP</sub>, the fault is cleared and charging resumes after V<sub>BUS</sub> is revalidated (see V<sub>BUS</sub> POR/Non-Compliant Charger Rejection).

### Charge Mode Battery Detection & Protection

#### VBAT Over-Voltage Protection

The OREG voltage regulation loop prevents V<sub>BAT</sub> from overshooting the OREG voltage when the battery is removed. If the VBAT Pin voltage is higher than 4.8V, the STAT pin pulses.

### Battery Detection During Charging

The IC can detect the presence, absence, or removal of a battery. During normal charging, once VBAT is close to VOREG and the termination charge current is detected, the IC terminates charging and turns on a discharge current, I<sub>DETECT</sub>, for 30ms. If VBAT is still above 2V, the battery is present. If VBAT is below 2V, the battery is

absent and IC enters No Battery Mode.

### Battery Short-Circuit Protection

If the battery voltage is below the short-circuit threshold ( $V_{SHORT}$ ); a linear current source,  $I_{SHORT}$ , supplies  $V_{BAT}$  until  $V_{BAT} > V_{SHORT}$ .

### NTC protection

NTC pin output 30uA current to NTC resistor (typical 10kΩ). When battery temperature rises to 50°C ( $V_{NTC}=120mV$ ) or falls to 0°C ( $V_{NTC}=0.9V$ ), the IC stops charging, and IC pulses the STAT pin. If NTC protection is not used, NTC pin must connect to 10kΩ normal resistor to ground.

### System Operation with No Battery

The DIO59121X continues charging after VBUS POR, regulating the  $V_{BAT}$  line to typical 3.8V. In this way, the DIO59121X can start the system without a battery. Re-connect power to VBUS or reset DISABLE pin, IC can exit No Battery Mode.

### Charger Status/Fault Status

The STAT pin indicates the operating condition of the IC and provides a fault indicator for interrupt driven systems.

**Table 1. STAT Pin Function**

Charge State	STAT Pin
No Charging	OPEN
Charging	LOW
Fault	2Hz Pulse

The types of fault in Charge Mode (see Table 2).

**Table 2. Fault Status During Charge Mode**

Fault Description
VBUS OVP
Sleep Mode
Poor Input Source
Battery OVP
Thermal Shutdown
No Battery
NTC protection

### PCB Layout Recommendations

Bypass capacitors should be placed as close to the IC as possible. In particular, the total loop length for CMID should be minimized to reduce overshoot and ringing on the SW, PMID, and VBUS pins. All power and ground pins must be routed to their bypass capacitors, using top copper whenever possible. Copper area connecting to the IC should be maximized to improve thermal performance if possible.

## CONTACT US

**Dioo** is a professional design and sales corporation for high-quality and performance analog semiconductors. The company focuses on industry markets, such as, cell phone, handheld products, laptop, and medical equipment and so on. Dioo's product families include analog signal processing and amplifying, LED drivers and charger IC. Go to <http://www.dioo.com> for a complete list of Dioo product families.

For additional product information, or full datasheet, please contact with our Sales Department or Representatives.

