

# DIO58056/B/C/D

## 50~1000mA, Single Cell Charger

### Features

- Broad Programmable Charging Current:  
50~1000mA
- Over-Temperature Protection
- Under Voltage Lockout Protection
- Reverse current protection between BAT and GND pins
- Programmable Charge Termination Current
- Maximum Voltage Power Input: 36V
- Automatic Recharge Threshold:  
DIO58056: 4.05V  
DIO58056B: 4.2V  
DIO58056C: 4.25V  
DIO58056D: 4.3V
- Final Float Voltage:  
DIO58056: 4.2V  
DIO58056B: 4.35V  
DIO58056C: 4.4V  
DIO58056D: 4.45V
- Charge Status Output Pin
- Trickle Charge Threshold  
DIO58056: 2.5V  
DIO58056B: 2.6V  
DIO58056C: 2.62V  
DIO58056D: 2.65V
- Soft-Start Limits Inrush Current
- Over Voltage Lockout Protection
- Package: DFN2\*2-8 and EP-SOIC8

### Descriptions

The DIO58056/B/C/D is a complete constant-current / constant voltage linear charger for single cell Lithium-Ion batteries. No external sense resistor is needed, and no blocking diode is required due to the internal MOSFET architecture. Thermal feedback regulates the charge current to limit the die temperature during high power operation or high ambient temperature. The charge voltage is fixed at 4.2V for DIO58056, 4.35V for DIO58056B, 4.4V for DIO58056C and 4.45V for DIO58056D and the charge current and the terminal current can be programmed externally with resistors. The input voltage is up to 36V.

When the input supply (wall adapter or USB supply) is removed, the DIO58056/B/C/D automatically enters a low current state, dropping the battery drain current to less than 1.0 $\mu$ A.

The DIO58056 is available in a small package with DFN2\*2-8 and EP-SOIC8. Standard product is Pb-Free.

### Applications

- Wireless phone
- MP3/MP4 Player
- Bluetooth device

### Ordering Information

Order Part Number	Top Marking		T <sub>A</sub>	Package	
DIO58056CN8	DEH6	Green	-40 to 85°C	DFN2*2-8	Tape & Reel, 3000
DIO58056BCN8	EH6B	Green	-40 to 85°C	DFN2*2-8	Tape & Reel, 3000
DIO58056CCN8	EH6C	Green	-40 to 85°C	DFN2*2-8	Tape & Reel, 3000
DIO58056DCN8	EH6D	Green	-40 to 85°C	DFN2*2-8	Tape & Reel, 3000
DIO58056XS8	DHVE6	Green	-40 to 85°C	EP-SOIC8	Tape & Reel, 2500

## Pin Assignment

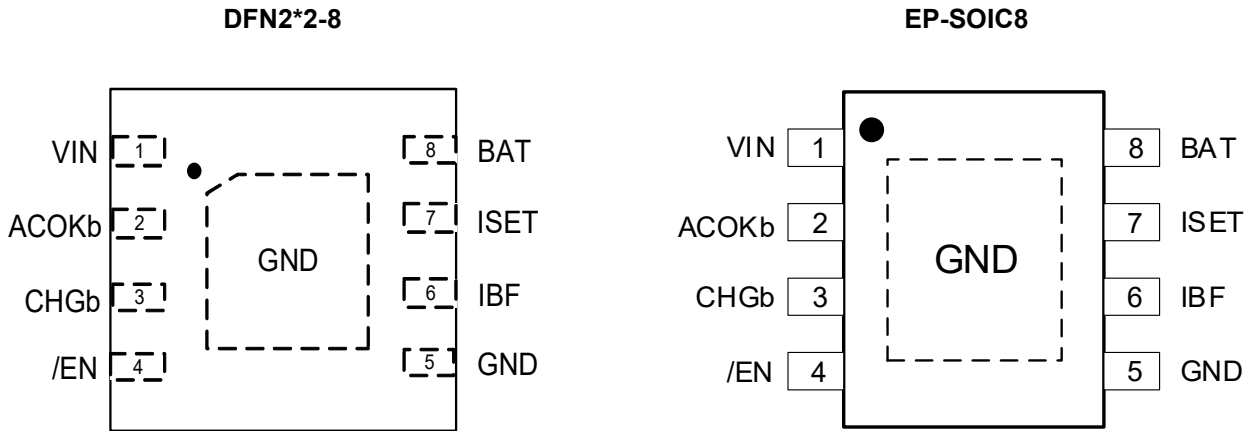

Figure 1. Top View

## Pin Descriptions

Name	Description
VIN	Power Supply. The absolute maximum input voltage is 36V.
ACOKb	Open-Drain Power Presence Indication. This pin is low if the voltage at the VIN pin is between UVP and OVP.
CHGb	Open-Drain Charge Status Output. This pin is low during charging.
/EN	Charger IC Enable. Drive to high to disable the charger. When this pin is driven to low or left floating, the charger is enabled. This pin has an internal 2MΩ pull-down resistor.
GND	Ground.
IBF	Terminal Current Programming Pin. This pin to an external resistor to program the charge termination current. See page 8 <b>Programming Charge termination</b> .
ISET	Charge current setting, charge current monitor and shutdown pin. The charging current is given by $I_{ISET} = (1/R_{ISET}) * 1000$ . The chip will be shutdown when ISET pin floating.
BAT	Charge Current Output. Provides charge current to the battery and regulates the final float voltage to 4.2V/4.35V/4.4V/4.45V.
GND(Exposed Pad)	This pin must be connected to GND, and punch to the main GND to facilitate heat dissipation.



# DIO58056/B/C/D

50~1000mA, Single Cell Charger

## Absolute Maximum Ratings

Stresses beyond those listed under "Absolute Maximum Rating" may cause permanent damage to the device. These are stress ratings only and functional operation of the device at these or any other condition beyond those indicated in the operational sections of the specifications is not implied. Exposure to absolute maximum rating conditions for extended periods may affect device reliability.

Parameter		Rating	Unit
Supply Voltage		-0.3 to 36	V
BAT Voltage		-0.3 to 10	V
Other Pin Voltage		-0.3 to 8	V
BAT Pin Current		1000	mA
Junction Temperature		160	°C
Operation Temperature		-40 to 85	°C
Storage Temperature		-65 to 125	°C
Lead Temperature (Soldering 10s)		260	°C
ESD	HBM	2500	V
Latch up		400	mA

## Recommend Operating Conditions

The Recommended Operating Conditions table defines the conditions for actual device operation. Recommended Operating conditions are specified to ensure optimal performance to the datasheet specifications. DIOO does not Recommend exceeding them or designing to Absolute Maximum Ratings.

Parameter		Rating	Unit
Input Supply Voltage	DIO58056	4.5 to 5.5	V
	DIO58056B	4.65 to 5.5	
	DIO58056C	4.7 to 5.5	
	DIO58056D	4.75 to 5.5	
Operating Temperature Range		-40 to 85	°C



# DIO58056/B/C/D

50~1000mA, Single Cell Charger

## Electrical Characteristics

$V_{IN}=5V$ ,  $T_A=25^{\circ}C$  (unless otherwise noted)

Symbol	Parameter	Conditions	Min.	Typ.	Max.	Unit	
I <sub>SPLYCHRG</sub>	Charge Mode Supply Current	R <sub>ISET</sub> =10kΩ		250	2000	μA	
		R <sub>ISET</sub> =20kΩ		180	2000	μA	
I <sub>BATCHRG</sub>	Charge Mode Battery Current	R <sub>ISET</sub> =1kΩ	900	1000	1100	mA	
		R <sub>ISET</sub> =10kΩ	90	100	110	mA	
		R <sub>ISET</sub> =20kΩ	44	49	54	mA	
V <sub>ISETCHRG</sub>	ISET Pin Voltage	R <sub>ISET</sub> =10kΩ	DIO58056	0.93	1.00	1.07	V
			DIO58056B	0.97	1.04	1.11	
			DIO58056C	0.98	1.05	1.12	
			DIO58056D	0.99	1.06	1.13	
I <sub>SPLYSTBY</sub>	Standby Mode Supply Current	Charge Terminated		73.8	120	μA	
I <sub>BATSTBY</sub>	Standby Mode Battery Current	Charge Terminated	0	±0.05	±1	μA	
I <sub>SPLYASD</sub>	Shutdown Mode Supply Current	V <sub>IN</sub> <V <sub>BAT</sub>	20	35	90	μA	
I <sub>BATASD</sub>	Shutdown Mode BAT Pin Current	V <sub>IN</sub> <V <sub>BAT</sub>		±0.05	±1	μA	
I <sub>SPLYUVLO</sub>	UVLO Mode Supply Current	V <sub>IN</sub> <V <sub>UV</sub>	20	35	90	μA	
I <sub>BATUVLO</sub>	UVLO Mode BAT Pin Current	V <sub>IN</sub> <V <sub>UV</sub>		±0.05	±1	μA	
I <sub>SPLYOVP</sub>	OVP Mode Supply Current	V <sub>IN</sub> >V <sub>OVP</sub>	20	35	90	μA	
I <sub>BATOVP</sub>	OVP Mode BAT Pin Current	V <sub>IN</sub> >V <sub>OVP</sub>		±0.05	±1	μA	
I <sub>BATMSD</sub>	Manual Shutdown BAT Pin Current	V <sub>ISET</sub> =1.3V		±0.05	±1	μA	
I <sub>BATSLEEP</sub>	Sleep Mode BAT Pin Current	V <sub>IN</sub> =0V		±0.05	±1	μA	
V <sub>/EN_VIH</sub>	/EN Pin Logic Input High		1.2			V	
V <sub>/EN_VIL</sub>	/EN Pin Logic Input Low				0.6	V	
R <sub>/EN_Pull Down</sub>	/EN Pin Internal Pull Down Resistance			2		MΩ	
I <sub>SPLYSHUT_/EN</sub>	Shutdown Mode Supply Current		20	70	100	μA	
I <sub>BATSHUT_/EN</sub>	Shutdown Mode BAT Pin Current			±0.05	±1	μA	
I <sub>Charge_terminated</sub>		R <sub>BF</sub> =51kΩ, R <sub>ISET</sub> =10kΩ		29		mA	
V <sub>Charge_terminated</sub>		R <sub>BF</sub> =51kΩ, R <sub>ISET</sub> =10kΩ		0.5		V	
V <sub>FLOAT</sub>	Float Voltage	DIO58056	4.158	4.2	4.242	V	
		DIO58056B	4.31	4.35	4.39		
		DIO58056C	4.36	4.4	4.44		
		DIO58056D	4.41	4.45	4.49		



## DIO58056/B/C/D

50~1000mA, Single Cell Charger

$I_{TRIKL}$	Trickle Charge Current	$R_{ISET}=10k\Omega$	8	10	12	mA	
$V_{TRIKL}$	Trickle Charge Voltage Threshold	$R_{ISET}=10k\Omega$	DIO58056	2.4	2.5	2.6	V
			DIO58056B	2.5	2.6	2.7	
			DIO58056C	2.52	2.62	2.72	
			DIO58056D	2.55	2.65	2.75	
$V_{TRIKL\_HYS}$	Trickle Charge Voltage Hysteresis	$R_{ISET}=10k\Omega$		100		mV	
$V_{UVLO}$	UVLO Threshold	From $V_{IN}$ Low to High	DIO58056	3.52	3.72	3.92	V
			DIO58056B	3.64	3.85	4.06	
			DIO58056C	3.69	3.9	4.11	
			DIO58056D	3.73	3.94	4.16	
$V_{UVLO\_HYS}$	UVLO Hysteresis			200		mV	
$V_{OVP}$	OVP Threshold	From $V_{IN}$ Low to High	DIO58056		6.4		V
			DIO58056B		6.6		
			DIO58056C		6.7		
			DIO58056D		6.8		
$V_{OVP\_HYS}$	OVP Hysteresis			320		mV	
$V_{MSD}$	Manual Shutdown Threshold Voltage	ISET Pin Rising		1.2	1.3	V	
		ISET Pin Falling		1.0		V	
$V_{ASD}$	$V_{IN}-V_{BAT}$ Lockout Threshold Voltage	$V_{IN}$ from low to High		120		mV	
		$V_{IN}$ from High to Low		80		mV	
$\Delta V_{RECHRG}$	Auto Recharge Battery Voltage		100	150	200	mV	
$V_{CHGb}$	CHGb Pin Output Low Voltage	$I_{CHGb}=5mA$		0.3	0.6	V	
$V_{ACOKb}$	ACOKb Pin Output Low Voltage			0.3	0.6	V	
$T_{LIM}$	Junction Temperature In CT Mode			160		°C	
$T_{SS}$	Soft-Start Time	$R_{ISET}=2k\Omega$		100		$\mu s$	
$T_{RECHRG}$	Recharge Comparator Filter Time			5		ms	
$T_{TERM}$	Termination Comparator Filter Time			8		ms	
$I_{ISET}$	ISET Pin Pull-up Current		0.1	0.5	1	$\mu A$	

Specifications subject to change without notice.

Typical Performance Characteristic

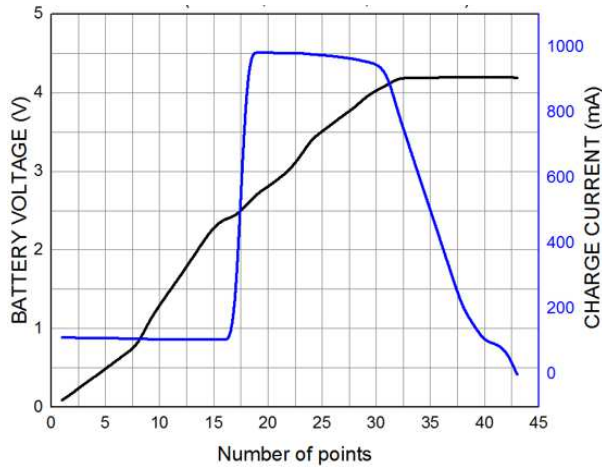

**Figure 2. Battery Charge Curve**  
(VCC=5V,RISET=1K,RIBF=22K)

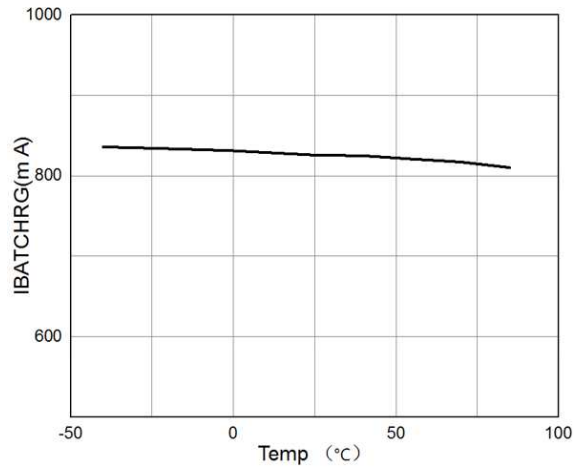

**Figure 3.  $I_{BATCHRG}$  vs Temp**  
(VCC=5V,RISET=1K)

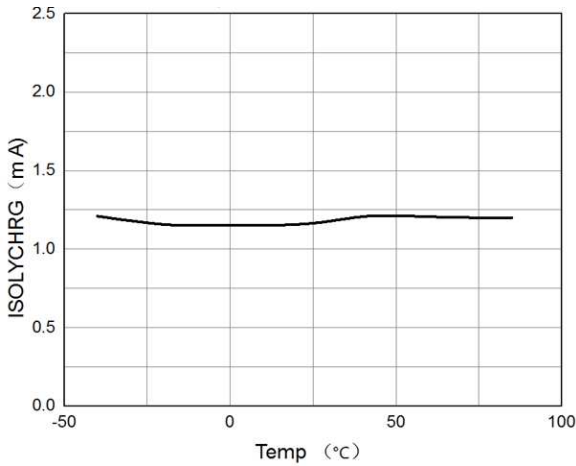

**Figure 4.  $I_{SOLYCHRG}$  vs Temp**  
(VCC=5V,RISET=1.2K)

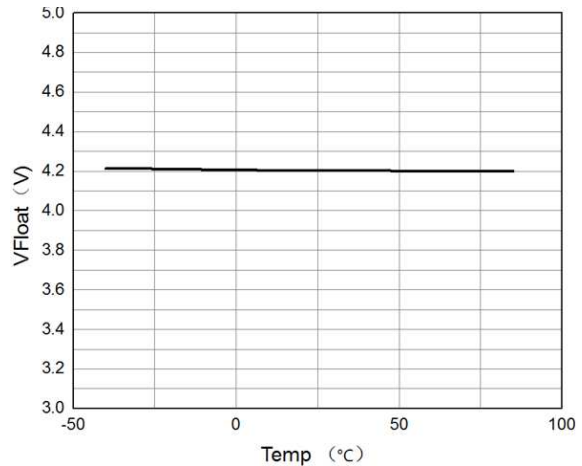

**Figure 5.  $V_{Float}$  vs Temp**  
(VCC=5V,RISET=10K)

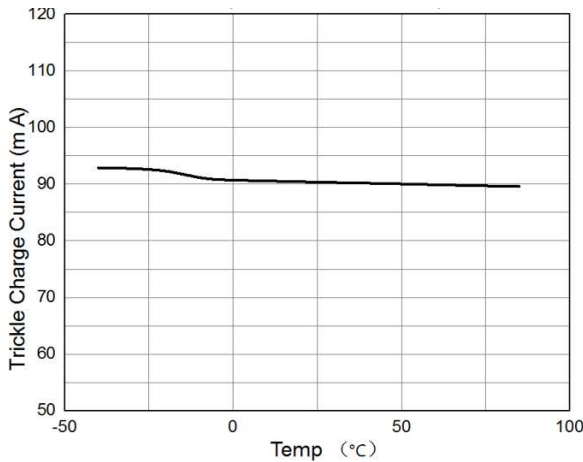

**Figure 6. Trickle Charge Current vs Temp**  
(VCC=5V,RISET=1.2K)

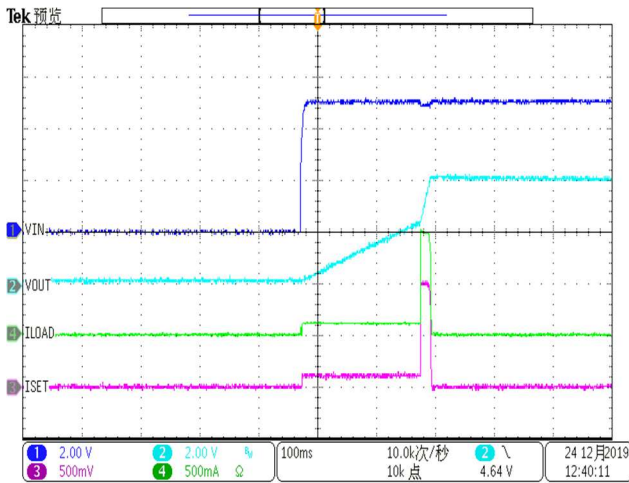

**Figure 7. Charging and discharging process**  
 ( $V_{IN}=5V$ ,  $R_{ISET}=1K\Omega$ ,  $C_{IN}=10\mu F$ ,  $C_{OUT}=10000\mu F$ ,  $EN=L$ )

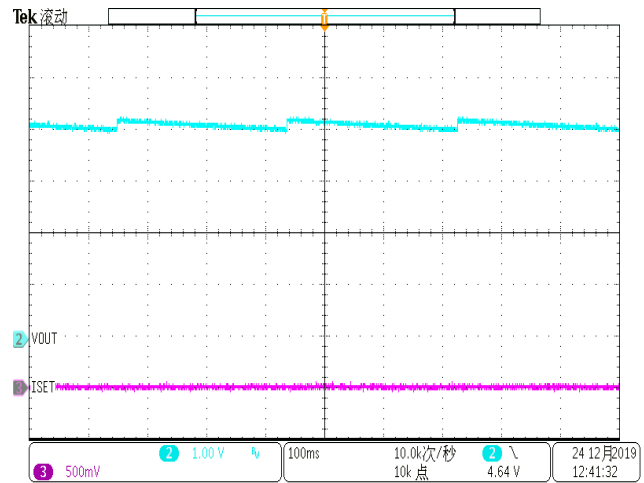

**Figure 8.  $V_{BAT\_FLOAT}$**   
 ( $V_{IN}=5V$ ,  $C_{IN}=C_{OUT}=10\mu F$ )

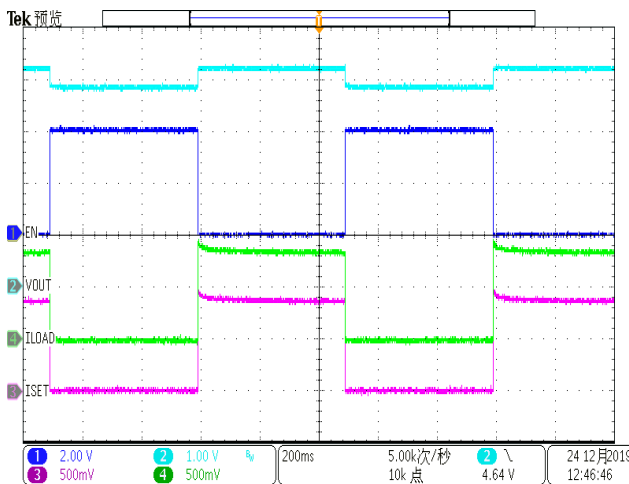

**Figure 9. /EN Turn On**  
 ( $V_{IN}=5V$ ,  $V_{BAT}=3.6V$ (Battery),  $C_{IN}=C_{OUT}=10\mu F$ ,  
 $R_{ISET}=1K\Omega$ ,  $V_{EN}=0\sim 4V$ )

## Operation information

The DIO58056/B/C/D is a single cell Lithium-Ion battery charger using a constant-current / constant-voltage algorithm. It can deliver up to 100mA of charge current with a final float voltage accuracy of  $\pm 1\%$ . The DIO58056/B/C/D includes an internal P-channel power MOSFET and thermal regulation circuitry. No blocking diode or external current sense resistor is required; thus, the basic charger circuit requires only two external components. Furthermore, the DIO58056/B/C/D is capable of operating from a USB power source.

### Normal charge cycle

A charge cycle begins when the voltage at the VIN pin rises above the UVLO threshold level and a 1% program resistor is connected from the ISET pin to ground or when a battery is connected to the charger output. If the BAT pin is less than 2.5V/2.6V/2.62V/2.65V, the charger enters trickle charge mode. In this mode, the DIO58056/B/C/D supplies approximately 1/10 the programmed charge current to bring the battery voltage up to a safe level for full current charging.



## DIO58056/B/C/D

When the BAT pin voltage rises above 2.5V/2.6V/2.62V/2.65V, the charger enters constant-current mode, where the programmed charge current is supplied to the battery. When the BAT pin approaches the final float voltage, the DIO58056/B/C/D enters constant-voltage mode and the charge current begins to decrease. The charge cycle ends when the IBF voltage is less than 500mV.

### Programming charge current

The charge current is programmed using a single resistor from the ISET pin to ground. The battery charge current of constant current mode is 1000 times the current out of the ISET pin. The program resistor and the charge current of constant current are calculated using the following equations:

$$I_{CHRG} = \left( \frac{1V}{R_{ISET}} \right) * 1000$$

### Programming Charge termination

The terminal current is programmed using a single resistor from the IBF pin to ground. When the IBF pin voltage falls below 500mV for longer than T<sub>TERM</sub> (typically 8ms), charging is terminated. The charge current is latched off and the DIO58056/B/C/D enters standby mode, where the input supply current drops to 130µA. The DIO58056/B/C/D terminates the charge cycle and ceases to provide any current through the BAT pin, the chip will be put into standby mode. In this state, all loads on the BAT pin must be supplied by the battery. The range of R<sub>BF</sub> is recommend: 5\*R<sub>ISET</sub> < R<sub>BF</sub> < 30\*R<sub>ISET</sub>.

V <sub>IN</sub> =5V, C <sub>IN</sub> =C <sub>OUT</sub> =10uF, R <sub>ISET</sub> =2K, I <sub>charge</sub> =500mA	
R <sub>IBF</sub>	I <sub>charge_terminated</sub> (mA) (Typ.)
75k	10
56K	15
47K	20
39K	25
36K	30
33K	35
30K	40
27K	45
25.5K	50
24K	55
22K	60
20K	65
19.1K	70
18K	75
17K	80
16K	85
15.8K	90
15	95
14.7k	100



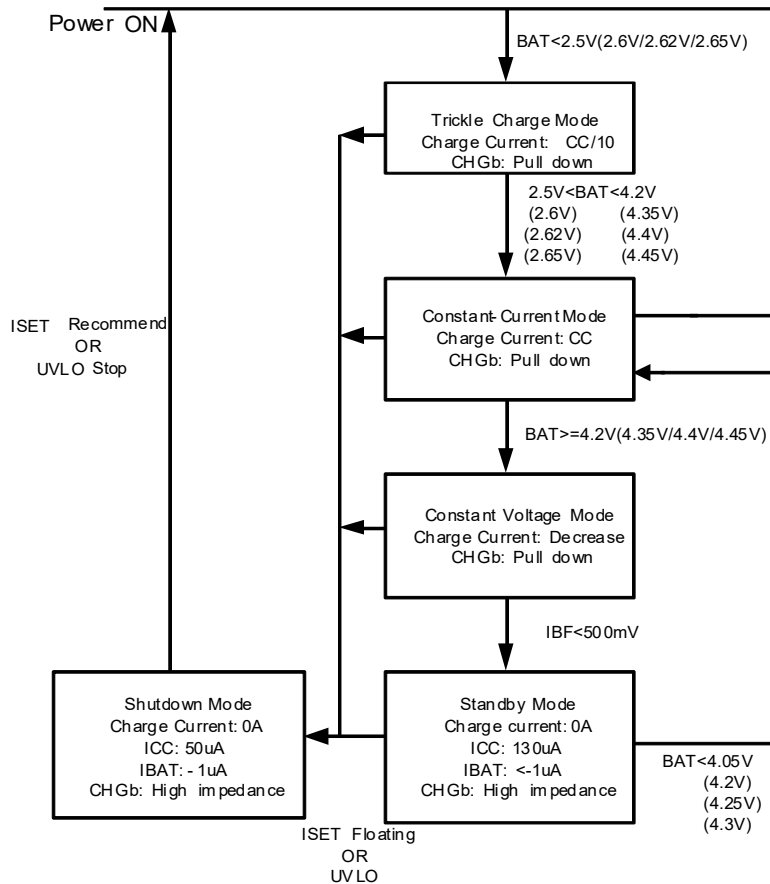

**Figure 10. State Diagram of a Typical Charge Cycle**

The DIO58056/B/C/D constantly monitors the BAT pin voltage in standby mode. If this voltage drops below the 4.05V/4.2V/4.25V/4.3V recharge threshold ( $V_{RECHRG}$ ), another charge cycle begins and current is once again supplied to the battery. The state diagram of a typical charge cycle is as Figure 10.

### Charge status indicator

DIO58056/B/C/D has an open-drain status indicator output CHGb. CHGb is pull-down when the DIO58056/B/C/D in a charge cycle. In other status CHGb is in high impedance.

### ACOK indicator

DIO58056/B/C/D has an open-drain status indicator output ACOKb. This pin is low if the voltage at the VIN pin is between UVP and OVP. In other status ACOKb is in high impedance.

### Thermal Limiting

An internal thermal feedback loop reduces the programmed charge current if the die temperature attempts to rise above a preset value of approximately 160°C. This feature protects the DIO58056/B/C/D from excessive temperature and allows the user to push the limits of the power handling capability of a given circuit board without risk of damaging the DIO58056/B/C/D. The charge current can be set according to typical (not worst-case) ambient temperature with the assurance that the charger will automatically reduce the current in worst-case conditions.

### Undervoltage Lockout (UVLO)

An internal undervoltage lockout circuit monitors the input voltage and keeps the charger in shutdown mode until VIN rises above the undervoltage lockout threshold. The UVLO circuit has a built-in hysteresis of 200mV. Furthermore, to protect against reverse current in the power MOSFET, the UVLO circuit keeps the charger in shutdown mode if VIN falls to within 50mV of the battery voltage. If the UVLO comparator is tripped, the charger will not come out of shutdown mode until VIN rises 120mV above the battery voltage.

### Overvoltage Lockout (OVLO)

An internal overvoltage lockout circuit monitors the input voltage and keeps the charger in shutdown mode until VIN fall down the overvoltage lockout threshold. The OVLO circuit has a built-in hysteresis of 320mV. Furthermore, to protect against reverse current in the power MOSFET, the OVLO circuit keeps the charger in shutdown mode if VIN falls to within 50mV of the battery voltage. If the OVLO comparator is tripped, the charger will not come out of shutdown mode until VIN rises 120mV above the battery voltage.

### EN Input

EN is an active-low logic input to enable the charger. Drive the EN pin to low or leave it floating to enable the charger. This pin has a 2MΩ internal pull-down resistor so when left floating, the input is equivalent to logic low. Drive this pin to high to disable the charger. The threshold for high is given in the Electrical Characteristics table.

### Manual Shutdown

At any point in the charge cycle, the DIO58056/B/C/D can be put into shutdown mode by removing R<sub>ISSET</sub> thus floating the ISET pin. A new charge cycle can be initiated by reconnecting the program resistor.

In manual shutdown, The CHGb pin is in a high impedance state if the DIO58056/B/C/D is in manual shutdown mode or in the undervoltage lockout mode: either VIN is within 120mV of the BAT pin voltage or insufficient voltage is applied to the VIN pin.

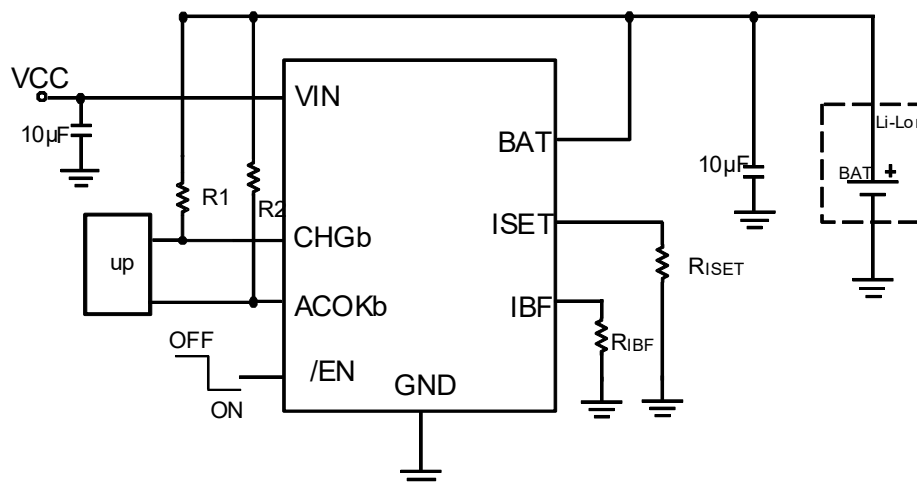

**Figure 11. Manual Shutdown Mode Application Circuit**

### Automatic recharge

Once the charge cycle is terminated, the DIO58056/B/C/D continuously monitors the voltage on the BAT pin using a comparator with a 5ms filter time ( $T_{RECHRG}$ ). A charge cycle restarts when the battery voltage falls below 4.05V/4.2V/4.25V/4.3V (Typ.) (which corresponds to approximately 80% to 90% battery capacity). This ensures

that the battery is kept at or near a fully charged condition and eliminates the need for periodic charge cycle initiations. CHGb output enters a pull-down state during recharge cycles.

## Application Information

### Typical Application

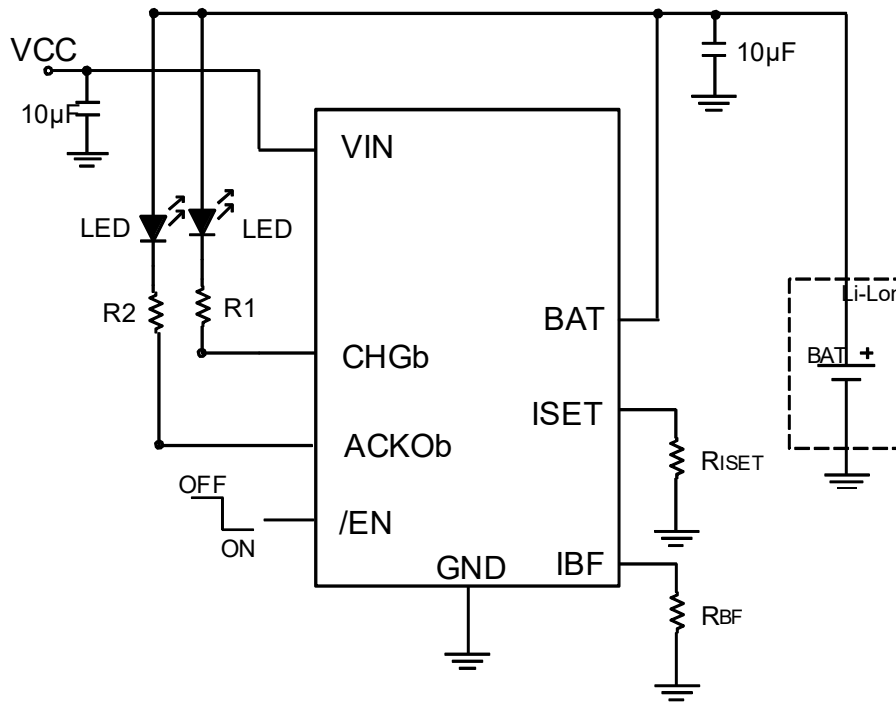

Figure 12. Typical applications W/T LED indicate

#### Stability considerations

The constant-voltage mode feedback loop is not stable without an output capacitor provided a battery is connected to the charger output. With no battery present, an output capacitor is recommended to reduce ripple voltage. When using high value, low ESR ceramic capacitors, it is recommended to add a 1Ω resistor in series with the capacitor. No series resistor is needed if tantalum capacitors are used.

In constant-current mode, the ISET pin is in the feedback loop, not the battery. The constant-current mode stability is affected by the impedance at the ISET pin. With no additional capacitance on the ISET pin, the charger is stable with program resistor values as high as 51KΩ. However, additional capacitance on this node reduces the maximum allowed program resistor thus it should be avoided.

#### Thermal Limit

An internal thermal feedback loop reduces the programmed charge current if the die temperature attempts to rise above a preset value of approximately 160°C. This feature protects the DIO58056/B/C/D from excessive temperature and allows the user to push the limits of the power handling capability of a given circuit board without risk of damaging the DIO58056/B/C/D. The charge current can be set according to typical (not worst-case) ambient temperature with the assurance that the charger will automatically reduce the current in worst-



## DIO58056/B/C/D

case conditions.

### Power dissipation

The conditions that cause the DIO58056/B/C/D to reduce charge current through thermal feed-back can be approximated by considering the power dissipated in the IC. Nearly all of this power dissipation is generated by the internal MOSFET. This is calculated to be approximately:

$$P_D = (V_{CC} - V_{BAT}) * I_{BAT}$$

It is important to remember that DIO58056/B/C/D applications do not be designed for worst-case thermal conditions since the IC will automatically reduce power dissipation when the junction temperature reaches approximately 160°C (Constant temperature mode).

### VIN bypass capacitor

Many types of capacitors can be used for input bypass, however, caution must be exercised when using multilayer ceramic capacitors. Because of the self-resonant and high Q characteristics of some types of ceramic capacitors, a 10µF ceramic capacitor is recommended for this bypass capacitor. Due to a high voltage transient will be generated under some start-up conditions, such as connecting the charger input to a live power source.

### Charge current soft-start

The DIO58056/B/C/D includes a soft-start circuit to minimize the inrush current at the start of a charge cycle. When a charge cycle is initiated, the charge current ramps from zero to the full-scale current over a period of approximately 100µs. This has the effect of minimizing the transient current load on the power supply during start-up.



## DIO58056/B/C/D

50~1000mA, Single Cell Charger

### CONTACT US

Dioo is a professional design and sales corporation for high-quality and performance analog semiconductors. The company focuses on industry markets, such as, cell phone, handheld products, laptop, and medical equipment and so on. Dioo's product families include analog signal processing and amplifying, LED drivers and charger IC. Go to <http://www.dioo.com> for a complete list of Dioo product families.

For additional product information, or full datasheet, please contact with our Sales Department or Representatives.