

DIO5644

Dual 1.5A Current Source Camera Flash LED Driver

Features

- Dual Independent 1.5A LED Current Source Programmability
- Accurate and Programmable LED Current Range from 1.4mA to 1.5A
- Optimized Flash LED Current During Low Battery Conditions (IVFM)
- >87% Efficiency in Torch Mode (@100mA) and Flash Mode (@1A to 1.5A)
- Grounded Cathode LED Operation for Improved Thermal Management
- Small Solution Size: <16mm
- Hardware Strobe Enable (STROBE)
- Synchronization Input for RF Power Amplifier Pulse Events (TX)
- Hardware Torch Enable (TORCH/TEMP)
- Remote NTC Monitoring (TORCH/TEMP)
- 400kHz I²C-Compatible Interface
7-Bit Address: 0x63

Descriptions

The DIO5644 is a dual LED flash drive that provides a high level of adjustability within a small solution size. The DIO5644 utilizes a 2MHz or 4MHz fixed-frequency synchronous boost converter to provide power to the dual 128 level current sources provide the flexibility to adjust the current ratios between LED1 and LED2. An adaptive regulation method ensures the current sources remain in regulation and maximizes efficiency.

Features of the DIO5644 are controlled via an I²C-compatible interface. These features include: hardware flash and hardware torch pins (STROBE and TORCH/TEMP), a TX interrupt, and an NTC thermistor monitor. The device offers independently programmable currents in each output leg to drive the LEDs in a Flash or Movie Mode (Torch) condition.

The 2-MHz or 4-MHz switching frequency options, overvoltage protection(OVP), and adjustable current limit allow for the use of tiny, low-profile inductors and (10μF) ceramic capacitors. The device operates over a -40°C to 85°C ambient temperature range.

Applications

- Camera Phone White LED Flash

Ordering Information

Order Part Number	Top Marking		T _A	Package	
DIO5644WL12	5644	RoHS or Green	-40 to +85°C	WLCSP-12	Tape & Reel, 3000

Pin Assignment

WLCSP-12 Pins

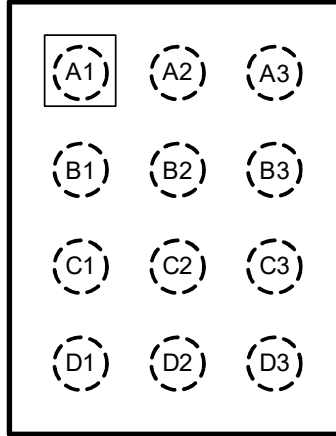

Figure 1. Top View

Pin Descriptions

PIN		Description
Number	Name	
A1	GND	Ground.
A2	IN	Input voltage connection. Connect IN to the input supply and bypass to GND with a 10µF or larger ceramic capacitor.
A3	SDA	Serial data input/output in the I ² C Mode on DIO5644.
B1	SW	Drain Connection for Internal NMOS and Synchronous PMOS Switches.
B2	STROBE	Active high hardware flash enable. Drive STROBE high to turn on Flash pulse. Internal pull-down resistor of 300kΩ between STROBE and GND.
B3	SCL	Serial clock input for DIO5644.
C1	OUT	Step-up DC/DC Converter Output. Connect a 10µF ceramic capacitor between this terminal and GND.
C2	HWEN	Active high enable pin. High=Standby, Low=Shutdown/Reset. Internal pull-down resistor of 300kΩ between HWEN and GND.
C3	TORCH/TEMP	Tor Terminal input or threshold detector for NTC temperature sensing and current scale back.
D1	LED2	High-side current source output flash LED.
D2	TX	Configurable dual polarity power amplifier synchronization input. Internal pull-down resistor of 300kΩ between TX and GND.
D3	LED1	High-side current source output for flash LED.



DIO5644

Dual 1.5A Current Source Camera Flash LED Driver

Absolute Maximum Ratings

Stresses beyond those listed under "Absolute Maximum Rating" may cause permanent damage to the device. These are stress ratings only and functional operation of the device at these or any other condition beyond those indicated in the operational sections of the specifications is not implied. Exposure to absolute maximum rating conditions for extended periods may affect device reliability.

Parameter		Rating	Unit
IN, SW, OUT, LED1, LED2		-0.3 to 6.0	V
SDA, SCL, TX, TORCH/TEMP, HWEN, STROBE		-0.3 to the lesser of (VIN+0.3)/6 V max	V
Continuous power dissipation		Internally limited	
Junction temperature (T _{J-MAX})		150	°C
Storage Temperature Range		-65 to 150	°C
Package Thermal Resistance θ_{JA} (WLCSP-12)		67.8	°C/W
ESD	HBM	4500	V

Recommend Operating Conditions

The Recommended Operating Conditions table defines the conditions for actual device operation. Recommended Operating conditions are specified to ensure optimal performance to the datasheet specifications. DIOO does not Recommend exceeding them or designing to Absolute Maximum Ratings.

Parameter		Rating	Unit
VIN		2.7 to 5.5	V
Junction temperature (T _J)		-40 to 125	°C
Ambient temperature (T _A)		-40 to 85	



DIO5644

Dual 1.5A Current Source Camera Flash LED Driver

Electrical Characteristics

Typical value: $V_{CC}=3.6V$, $HWEN=V_{IN}$, $T_A = 25^{\circ}C$, unless otherwise specified.

Symbol	Parameter	Conditions	Min.	Typ.	Max.	Unit
Current Source Specifications						
$I_{LED1/2}$	Current source accuracy	$V_{OUT}=4V$, flash code=0x7F=1.5A flash	-7%	1.5	7%	A
		$V_{OUT}=4V$, flash code=0x7F=90mA Torch	-10%	92.8	10%	mA
V_{HR}	LED1 and LED2 current source regulation voltage	$I_{LED1/2}=729mA$ Flash		290		mV
		$I_{LED1/2}=179mA$ Torch		158		
V_{OVP}		ON threshold	4.86	5	5.1	V
		OFF threshold	4.75	4.88	4.99	
Step-up DC/DC Converter Specifications						
R_{PMOS}	PMOS switch on-resistance			86		m Ω
R_{NMOS}	NMOS switch on-resistance			65		
I_{CL}	Switch current limit	Reg 0x07, bit[0]=0	-12%	2.7	12%	A
		Reg 0x07, bit[0]=1	-12%	3.8	12%	
UVLO	Under voltage lockout threshold	Falling V_{IN}			2.65	V
V_{TRIP}	NTC comparator trip threshold	Reg 0x09, bits[3:1]='100'	-5%	0.6	5%	V
I_{NTC}	NTC current		-6%	50	6%	μA
V_{IVFM}	Input voltage flash monitor trip threshold	Reg 0x09, bits[3:1]='000'	-3%	2.9	3%	V
I_Q	Quiescent supply current	Device not switching pass mode		0.3	0.75	mA
I_{SD}	Shutdown supply current	Device disabled, $HWEN=0V$, $2.7V \leq V_{IN} \leq 5.5V$		0.1	4	μA
I_{SB}	Standby supply current	Device disabled, $HWEN=1.8V$, $2.7V \leq V_{IN} \leq 5.5V$		2.5	10	μA
HWEN, TORCH/TEMP, STROBE, TX Voltage Specifications						
V_{IL}	Input logic low	$2.7V \leq V_{IN} \leq 5.5V$	0		0.4	V
V_{IH}	Input logic high		1.2		V_{IN}	
I²C-Compatible Interface Specifications (SCL,SDA)						
V_{IL}	Input logic low	$2.7V \leq V_{IN} \leq 5.5V$	0		0.4	V
V_{IH}	Input logic high		1.2		V_{IN}	
V_{OL}	Output logic low	$I_{LOAD}=3mA$			400	mV
Timing Requirements						
t_1	SCL clock period		2.4			μs
t_2	Data in set-up time to SCL high		100			ns



DIO5644

t3	Data out stable After SCL low		0			
t4	SDA low set-up time to SCL Low (start)		100			
t5	SDA high hold time after SCL high (stop)		100			
Switching Characteristics						
f _{sw}	Switching frequency	2.7V ≤ V _{IN} ≤ 5.5V	-6%	4	6%	MHz

Specifications subject to change without notice.

Detailed Description

Overview

The DIO5644 is a high-power white LED flash driver capable of delivering up to 1.5A in either of the two parallel LEDs. The device incorporates a 2MHz or 4MHz constant frequency-synchronous current-mode PWM boost converter and dual high-side current sources to regulate the LED current over the 2.7V to 5.5V input voltage range.

The DIO5644 PWM DC/DC boost converter switches and boosts the output to maintain at least V_HR across each of the current sources (LED1/2). This minimum headroom voltage ensures that both current sources remain in regulation. If the input voltage is above the LED voltage + current source headroom voltage the device does not switch, but turns the PFET on continuously (Pass mode). In Pass mode the difference between (V_{IN} - I_{LED} × R_{PMOS}) and the voltage across the LED is dropped across the current source.

The DIO5644 has three logic inputs including a hardware Flash Enable (STROBE). A hardware Torch Enable (TORCH/TEMP, TORCH= default), and a Flash Interrupt input (TX) designed to interrupt the flash pulse during high battery-current conditions. These logic inputs have internal 300kΩ (typ.) pull-down resistors to GND.

Additional features of the DIO5644 include an internal comparator for LED thermal sensing via an external NTC thermistor and an input voltage monitor that can reduce the Flash current during low V_{IN} conditions. It also has a Hardware Enable (HWEN) pin that can be used to reset the state of the device and the registers by pulling the HWEN pin to ground.

Control is done via an I²C compatible INTERFACE. This includes adjustment of the Flash and Torch current levels, changing the Flash Timeout Duration, and changing the switch current limit. Additionally, there are flag and status bits that indicate flash current time-out, LED over temperature condition, LED failure (open/short), device thermal shutdown, TX interrupt, and V_{IN} under under-voltage conditions.

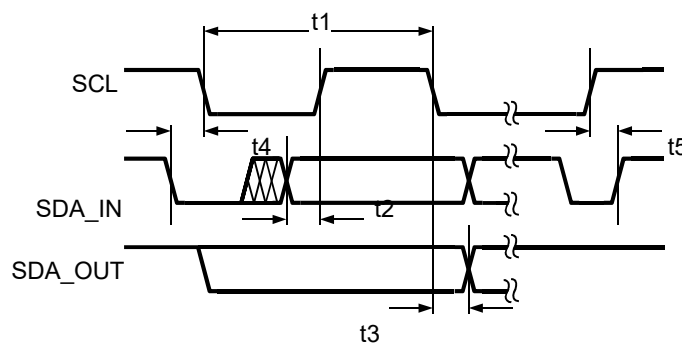

Figure 2. I²C-Compatible Interface Specifications

Functional Block Diagram

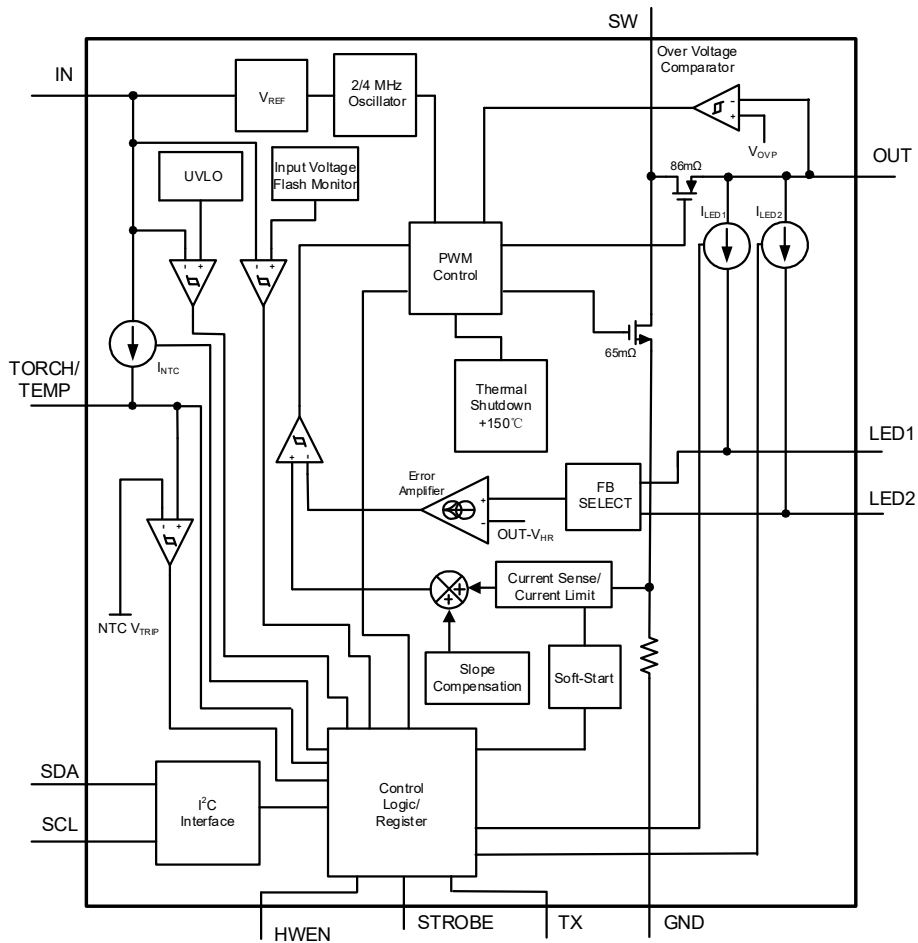

Figure 3. Functional Block Diagram

Application Circuit

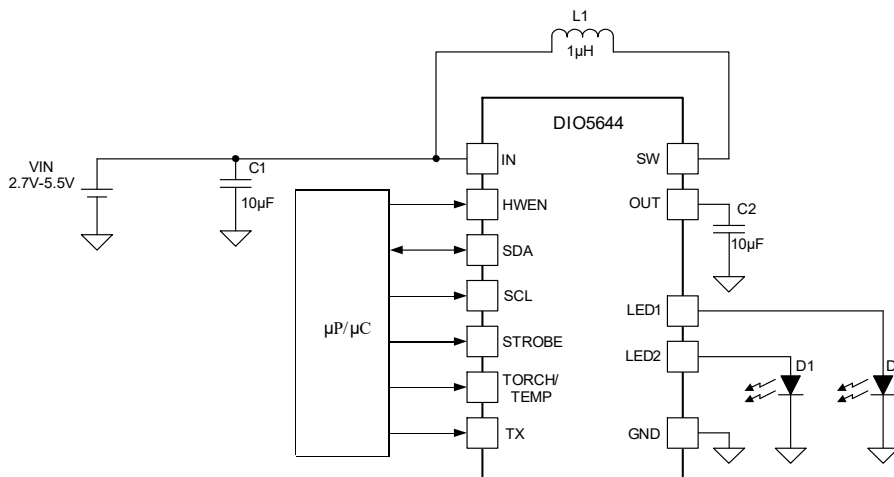

Figure 4. Application Circuit

Operation Principle

Flash Mode

In Flash Mode, the LED current sources (LED1/2) provide 128 target current levels from 10.9mA to 1500mA. Once the Flash sequence is activated the current source (LED) ramps up to the programmed Flash current by stepping through all current steps until the programmed current is reached. The headroom in the two current sources can be regulated to provide 10.9mA to 1.5A on each of the two output legs. There is an option in the register settings to keep the two currents in the output leg the same.

When the device is enabled in Flash Mode through the Enable Register, all mode bits in the Enable Register are cleared after a flash time-out event.

Torch Mode

In Torch mode, the LED current sources (LED1/2) provide 128 target current levels from 0.977mA to 179mA or 1.954mA to 360mA. The Torch currents are adjusted via the LED1 and LED2 LED Torch Brightness Registers. Torch mode is activated by the Enable Register (setting M1, M0 to '10'), or by pulling the TORCH/TEMP pin HIGH when the pin is enabled (Enable Register) and set to Torch Mode. Once the TORCH sequence is activated the active current sources (LED1/2) ramps up to the programmed Torch current by stepping through all current steps until the programmed current is reached. The rate at which the current ramps is determined by the value chosen in the Timing Register.

Torch Mode is not affected by Flash Timeout or by a TX Interrupt event.

IR Mode

In IR Mode, the target LED current is equal to the value stored in the LED1/2 Flash Brightness Registers. When IR mode is enabled (setting M1, M0 to '01'), the boost converter turns on and set the output equal to the input (pass-mode). At this point, toggling the STROBE pin enables and disables the LED1/2 current sources (if enabled). The strobe pin can only be set to be Level sensitive, meaning all timing of the IR pulse is externally controlled. In IR Mode, the current sources do not ramp the LED outputs to the target. The current transitions immediately from off to on and then on to off.

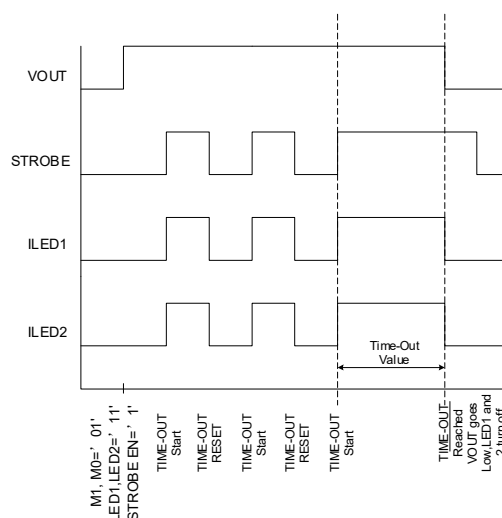

Figure 5. IR Mode Timeout



DIO5644

Device Functioning Modes

Start-Up (Enabling The Device)

Turn on of the DIO5644 Torch and Flash modes can be done through the Enable Register. On start-up, when V_{OUT} is less than V_{IN} the internal synchronous PFET turns on as a current source and delivers 200mA (typ.) to the output capacitor. During this time the current source (LED) is off. When the voltage across the output capacitor reaches 2.2V (typ.) the current source turns on. At turn-on the current source steps through each FLASH or TORCH level until the target LED current is reached. This gives the device a controlled turn-on and limits inrush current from the V_{IN} supply.

Pass Mode

The DIO5644 starts up in Pass Mode and stays there until Boost Mode is needed to maintain regulation. If the voltage difference between V_{OUT} and V_{LED} falls below V_{HR} , the device switches to Boost Mode. In Pass Mode the boost converter does not switch, and the synchronous PFET turns fully on bringing V_{OUT} up to $V_{IN} - I_{LED} \times R_{PMOS}$. In Pass Mode the inductor current is not limited by the peak current limit.

Power Amplifier Synchronization (TX)

The TX pin is a Power Amplifier Synchronization input. This is designed to reduce the flash LED current and thus limit the battery current during high battery current conditions such as PA transmit events. When the DIO5644 is engaged in a Flash event, and the TX pin is pulled high, the LED current is forced into Torch Mode at the programmed Torch current setting. If the TX pin is then pulled low before the Flash pulse terminates, the LED current returns to the previous Flash current level. At the end of the Flash time-out, whether the TX pin is high or low, the LED current turns off.

Input Voltage Flash Monitor (IVFM)

The DIO5644 has the ability to adjust the flash current based upon the voltage level present at the IN pin utilizing the Input Voltage Flash Monitor (IVFM). The adjustable threshold IVFM-D ranges from 2.9V to 3.6V in 100-mV steps, with usage mode (Down Mode). The Flags2 Register has the IVFM flag bit set when the input voltage crosses the IVFM-D value. Additionally, the IVFM-D threshold sets the input voltage boundary that forces the DIO5644 to stop ramping the flash current during start-up (Down Mode).

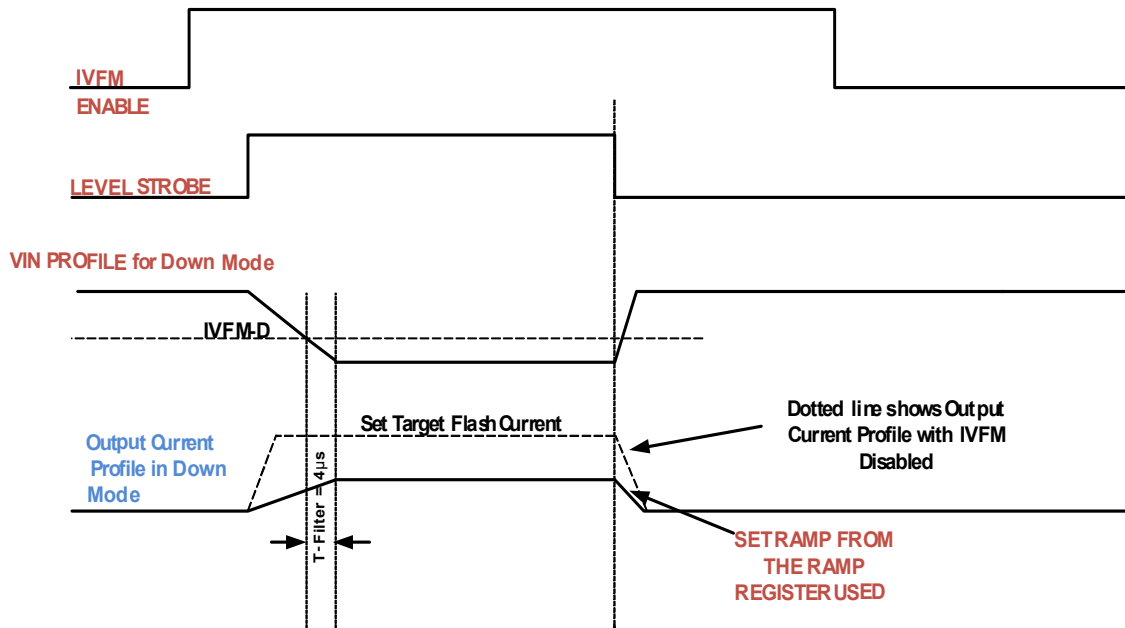

Figure 6. Down Mode

Fault/Protections

Fault Operation

If the DIO5644 enters a fault condition, the device sets the appropriate flag in the Flags1 and Flags2 Registers (0x0A and 0x0B), and place the device into standby by clearing the Mode Bits ([1],[0]) in the Enable Register. The DIO5644 remains in standby until an I²C read of the Flags1 and Flags2 Registers are completed. Upon clearing the flags/faults, the device can be restarted (Flash, Torch, IR, etc.). If the fault is still present, the DIO5644 re-enters the fault state and enters standby again.

Flash Time-Out

The Flash Time-Out period sets the amount of time that the Flash Current is being sourced from the current sources (LED1/2). The DIO5644 has 16 timeout levels ranging from 10ms to 400ms or 40ms to 1600ms (See Timing Configuration register (0x08) for more detail).

Overvoltage Protection (OVP)

The output voltage is limited to typically 5V. In situations such as an open LED, the DIO5644 raises the output voltage in order to try and keep the LED current at its target value. When V_{OUT} reaches 5V (typ.) the overvoltage comparator trips and turns off the internal NFET. When V_{OUT} falls below the “V_{OVP off Threshold}”, the DIO5644 begins switching again. The mode bits are cleared, and the OVP flag is set, when an OVP condition is present for three rising OVP edges. This prevents momentary OVP events from forcing the device to shut down.

Current Limit

The DIO5644 features two selectable inductor current limits that are programmable through the I²C-compatible interface. When the inductor current limit is reached, the DIO5644 terminates the charging phase of the switching cycle. Switching resumes at the start of the next switching period. If the over-current condition persists, the device operates continuously in current limit.

Since the current limit is sensed in the NMOS switch, there is no mechanism to limit the current when the device operates in Pass Mode (current does not flow through the NMOS in pass mode). In Boost mode or Pass mode if V_{OUT} falls below 2.3V, the device stops switching, and the PFET operates as a current source limiting the current to 200mA. This prevents damage to the DIO5644 and excessive current draw from the battery during output short-circuit conditions. The mode bits are not cleared upon a Current Limit event, but a flag is set.

NTC Thermistor Input (Torch/Temp)

The TORCH/TEMP pin, when set to TEMP mode, serves as a threshold as a threshold detector and bias source for negative temperature coefficient (NTC) thermistors. When the voltage at TEMP goes below the programmed threshold, the DIO5644 is placed into standby mode. The NTC threshold voltage is adjustable from 200mV to 900mV in 100mV steps. The NTC bias current is set to 50 μ A. The NTC detection circuitry can be enabled or disabled via the Enable Register. If enabled, the NTC block turns on and off during the start and stop of a Flash/Torch event.

Additionally, the NTC input looks for an open NTC connection and a shorted NTC connection. If the NTC input falls below 100mV, the NTC short flag is set, and the device is disabled. If the NTC input rises above 2.3V, the NTC Open flag is set, and the device is disabled. These fault detections can be individually disabled/enabled via the NTC Open Fault Enable bit and the NTC Short Fault Enable bit.

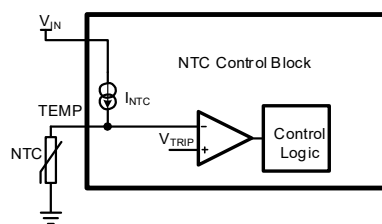

Figure 7. Temp Detection Diagram

Under voltage Lockout (UVLO)

The DIO5644 has an internal comparator that monitors the voltage at IN and forces the DIO5644 into standby if the input voltage drops to 2.5V. If the UVLO monitor threshold is tripped, the UVLO flag bit is set in the Flags1 Register (0x0A). If the input voltage rises above 2.7V, the DIO5644 is not available for operation until there is an I²C read of the Flags1 Register (0x0A). Upon a read, the Flags1 register is cleared, and normal operation can resume if the input voltage is greater than 2.7V.

Thermal Shutdown (TSD)

When the DIO5644 die temperature reaches 150°C, the thermal shutdown detection circuit trips, forcing the



DIO5644

DIO5644 into standby and writing a '1' to the corresponding bit of the Flags1 Register (0x0A) (Thermal Shutdown bit). The DIO5644 is only allowed to restart after the Flags1 Register (0x0A) is read, clearing the fault flag. Upon restart, if the die temperature is still above 150°C, the DIO5644 resets the Fault flag and re-enters standby.

LED and/or VOUT Short Fault

The LED Fault flags read back a '1' if the device is active in Flash or Torch mode and either active LED output experiences a short condition. The Output Short Fault flag reads back a '1' if the device is active in Flash or Torch mode and the boost output experiences a short condition. An LED short condition is determined if the voltage at LED1 or LED2 goes below 500mV(typ.) while the device is in Torch or Flash mode. There is a deglitch time of 256µs before the LED Short flag is valid and a deglitch time of 2.048ms before the VOUT Short flag is valid. The LED Short Faults can be reset to '0' by removing power to the DIO5644, setting HWEN to '0', setting the SW RESET bit to a '1', or by reading back the Flags1 Register. The mode bits are cleared upon an LED and/or V_{OUT} short fault.

Programming

Control Truth Table

MODE1	MODE0	STROBE EN	TORCH EN	STROBE PIN	TORCH PIN	ACTION
0	0	0	0	X	X	Standby
0	0	0	1	X	pos edge	Ext Torch
0	0	1	0	pos edge	X	Ext Flash
0	0	1	1	0	pos edge	Standalone Torch
0	0	1	1	pos edge	pos edge	Standalone Flash
0	0	1	1	pos edge	X	Standalone Flash
1	0	X	X	X	X	Int Torch
1	1	X	X	X	X	Int Flash
0	1	0	X	X	X	IRLED Standby
0	1	1	X	0	X	IRLED Standby
0	1	1	X	pos edge	X	IRLED Standby

I²C Compatible Interface

Data Validity

The data on SDA must be stable during the HIGH period of the clock signal (SCL). In other words, the state of the data line can only be changed when SCL is LOW.

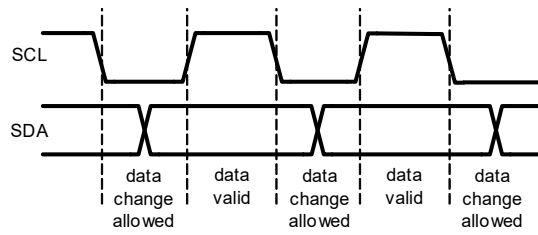

Figure 8. Data Validity Data

A pull-up resistor between the controller's VIO line and SDA must be greater than $[(VIO-V_{OL})/3mA]$ to meet the V_{OL} requirement on SDA. Using a larger pull-up resistor results in lower switching current with slower edges, while using a smaller pull-up results in higher switching currents with faster edges.

Start and Stop Conditions

START and STOP conditions classify the beginning and the end of the I²C session. A START condition is defined as the SDA signal transitioning from HIGH to LOW while SCL line is HIGH. A STOP condition is defined as the SDA transitioning from LOW to HIGH while SCL is HIGH. The I²C master always generates START and STOP conditions. The I²C bus is considered busy after a START condition and free after a STOP condition. During data transmission, the I²C master can generate repeated START conditions. First START and repeated START conditions are equivalent, function-wise.

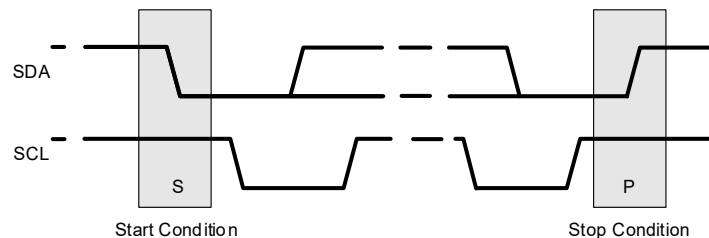

Figure 9. Start and Stop Conditions

Transferring Data

Every byte put on the SDA line must be eight bits long, with the most significant bit (MSB) transferred first. Each byte of data has to be followed by an acknowledge bit. The acknowledge related clock pulse is generated by the master. The master releases the SDA line (HIGH) during the acknowledge clock pulse. The DIO5644 pulls down the SDA line during the 9th clock pulse, signifying an acknowledge. The DIO5644 generates an acknowledge after each byte is received. There is no acknowledge created after data is read from the device.

After the START condition, the I²C master sends a chip address. This address is seven bits long followed by an eighth bit which is a data direction bit (R/W). The DIO5644 7-bit address is 0x63. For the eighth bit, a '0' indicates a WRITE and a '1' indicates a READ. The second byte selects the register to which the data is written. The third byte contains data to write to the selected register.

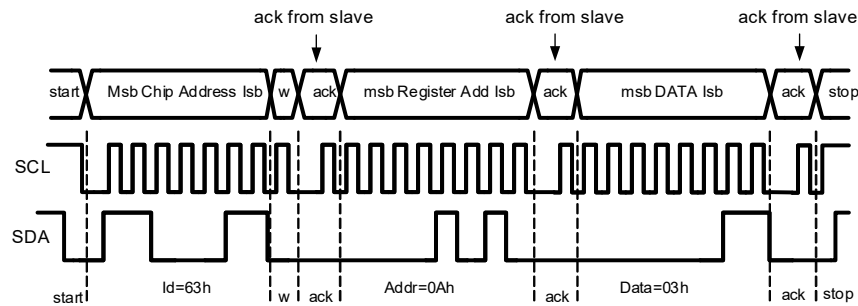

Figure 10. Write Cycle W=Write (SDA="0") R=Read (SDA="1") Ack=Acknowledge (SDA Pulled Down by Either Master or Slave) ID=Chip Address

I²C Compatible Chip Address

The device address for the DIO5644 is 1100011 (0x63). After the START condition, the I²C-compatible master sends the 7-bit address followed by an eighth read or write bit (R/W). R/W = 0 indicates a WRITE and R/W = 1 indicates a READ. The second byte following the device address selects the register address to which the data is written. The third byte contains the data for the selected register.

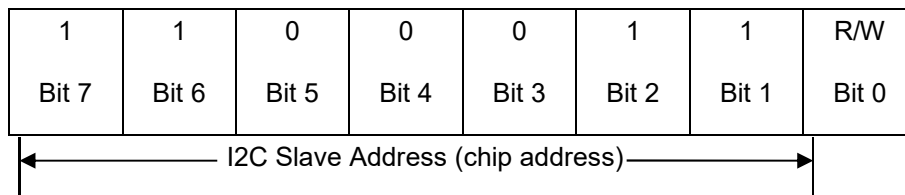

Figure 11. I²C Compatible Chip Address

Register Descriptions

Register Name	Internal HEX Address	Power ON/Reset Value
		DIO5644
Enable Register	0x01	0x80
IVFM Register	0x02	0x01
LED1 Flash Brightness Register	0x03	0xBF
LED2 Flash Brightness Register	0x04	0x3F
LED1 Torch Brightness Register	0x05	0xBF
LED2 Torch Brightness Register	0x06	0x3F
Boost Configuration Register	0x07	0x09
Timing Configuration Register	0x08	0x1A
TEMP Register	0x09	0x08
Flags1 Register	0x0A	0x00
Flags2 Register	0x0B	0x00
Device ID Register	0x0C	0x02



DIO5644

Enable Register (0x01)

Bit 7	Bit 6	Bit 5	Bit 4	Bit 3	Bit 2	Bit 1	Bit 0
TX Pin Enable 0 = Disabled 1 = Enabled (Default)	Strobe Type 0 = Level Triggered (Default) 1 = Edge Triggered	Strobe Enable 0 = Disabled (Default) 1 = Enabled	TORCH/TEMP Pin Enable 0 = Disabled (Default) 1 = Enabled	Mode Bits: M1, M0 '00' = Standby (Default) '01' = IR Drive '10' = Torch '11' = Flash		LED2 Enable 0 = OFF (Default) 1 = ON	LED1 Enable 0 = OFF (Default) 1 = ON

IVFM Register (0x02)

Bit 7	Bit 6	Bit 5	Bit 4	Bit 3	Bit 2	Bit 1	Bit 0
RFU	UVLO Circuitry (Default) 0 = Disabled (Default) 1 = Enabled	IVFM Levels 000 = 2.9V (Default) 001 = 3V 010 = 3.1V 011 = 3.2V 100 = 3.3V 101 = 3.4V 110 = 3.5V 111 = 3.6V			IVFM Hysteresis 0 = 0mV (Default) 1 = 50mV	IVFM Selection 00 = Disabled X1 = Down Mode	

LED1 Flash Brightness Register (0x03)

Bit 7	Bit 6	Bit 5	Bit 4	Bit 3	Bit 2	Bit 1	Bit 0
LED2 Flash Current Override 0 = LED2 Flash Current is not set to LED1 Flash 1 = LED2 Flash Current is set to LED1 Flash Current (Default)	LED1 Flash Brightness Level $I_{FLASH1/2} (mA) \approx (Brightness\ Code \times 11.725\ mA) + 10.9mA$ 0000000 = 10.9mA 0111111 = 729mA (Default) 1111111 = 1.5A						

LED2 Flash Brightness Register (0x04)

Bit 7	Bit 6	Bit 5	Bit 4	Bit 3	Bit 2	Bit 1	Bit 0
RFU	LED2 Flash Brightness Levels $I_{FLASH1/2} (mA) \approx (Brightness\ Code \times 11.725\ mA) + 10.9mA$ 0000000 = 10.9mA 0111111 = 729mA (Default) 1111111 = 1.5A						

LED1 Torch Brightness Register (0x05)

Bit 7	Bit 6	Bit 5	Bit 4	Bit 3	Bit 2	Bit 1	Bit 0
LED2 Torch Current Override 0 = LED2 Torch Current is not set to LED1 Torch Current 1 = LED2 Torch Current is set to LED1 Torch Current (Default)	LED1 Torch Brightness Levels $I_{TORCH1/2} (mA) \approx (Brightness\ Code \times 1.4\ mA) + 0.977mA$ 0000000 = 0.977mA 0111111 = 89.3mA (Default) 1111111 = 179mA						

LED2 Torch Brightness Register (0x06)

Bit 7	Bit 6	Bit 5	Bit 4	Bit 3	Bit 2	Bit 1	Bit 0
Torch Current Double Bit 0 = Torch current*1 (Default) 1 = Torch current*2	LED2 Torch Brightness Levels $I_{TORCH1/2} (mA) \approx (Brightness\ Code \times 1.4\ mA) + 0.977mA$ 0000000 = 0.977mA 0111111 = 89.3mA (Default) 1111111 = 179mA						



DIO5644

Boost Configuration Register (0x07)

Bit 7	Bit 6	Bit 5	Bit 4	Bit 3	Bit 2	Bit 1	Bit 0
Software Reset Bit 0 = Not Reset (Default) 1 = Reset	RFU	RFU	RFU	LED Pin Short Fault Detect 0 = Disable 1 = Enable (Default)	Boost Mode (Default) 0 = Normal 1 = Pass Mode Only	Boost Frequency Select 0 = 2MHz (Default) 1 = 4MHz	Boost Current Limit Setting 0 = 2.7A 1 = 3.8A (Default)

Timing Configuration Register (0x08)

Bit 7	Bit 6	Bit 5	Bit 4	Bit 3	Bit 2	Bit 1	Bit 0
Flash Time Quadruple Bit 0=flash time*1 (Default) 1=flash time*4	Torch Current Ramp Time 000 = No Ramp 001 = 1ms (Default) 010 = 32ms 011 = 64ms 100 = 128ms 101 = 256ms 110 = 512ms 111 = 1024ms			Flash Time-Out Duration 0000 = 10ms 0001 = 20ms 0010 = 30ms 0011 = 40ms 0100 = 50ms 0101 = 60ms 0110 = 70ms 0111 = 80ms 1000 = 90ms 1001 = 100ms 1010 = 150ms (Default) 1011 = 200ms 1100 = 250ms 1101 = 300ms 1110 = 350ms 1111 = 400ms			

TEMP Register (0x09)

Bit 7	Bit 6	Bit 5	Bit 4	Bit 3	Bit 2	Bit 1	Bit 0
RFU	TORCH Polarity 0 = Active High (Default) (Pull-down Resistor Enabled) 1 = Active Low (Pull-down Resistor Disabled)	NTC Open Fault Enable 0 = Disabled (Default) 1 = Enable	NTC Short Fault Enable 0 = Disabled (Default) 1 = Enable	TEMP Detect Voltage Threshold 000 = 0.2V 001 = 0.3V 010 = 0.4V 011 = 0.5V 100 = 0.6V (Default) 101 = 0.7V 110 = 0.8V 111 = 0.9V		TORCH/TEMP Function Select 0 = TORCH (Default) 1 = TEMP	

Flags1 Register (0x0A)

Bit 7	Bit 6	Bit 5	Bit 4	Bit 3	Bit 2	Bit 1	Bit 0
TX Flag	V _{OUT} Short Fault	VLED1 Short Fault	VLED2 Short Fault	Current Limit Flag	Thermal Shutdown (TSD) Fault	UVLO Fault	Flash Time-Out Flag

Flags2 Register (0x0B)

Bit 7	Bit 6	Bit 5	Bit 4	Bit 3	Bit 2	Bit 1	Bit 0
RFU	RFU	RFU	NTC Short Fault	NTC Open Fault	IVFM Trip Flag	OVP Fault	TEMP Trip Fault

Device ID Register (0x0C)

Bit 7	Bit 6	Bit 5	Bit 4	Bit 3	Bit 2	Bit 1	Bit 0
RFU	RFU	Device ID '000'			Silicon Revision Bit '010'		

Detailed Design Procedure**Output Capacitor Selection**

The DIO5644 is designed to operate with a 10µF ceramic output capacitor. When the boost converter is running, the output capacitor supplies the load current during the boost converter on-time. When the NMOS switch turns off, the inductor energy is discharged through the internal PMOS switch, supplying power to the load and restoring charge to the output capacitor. This causes a sag in the output voltage during the on-time and a rise in the output voltage during the off-time. The output capacitor is therefore chosen to limit the output ripple to an acceptable level depending on load current and input/output voltage differentials and also to ensure the converter remains stable.

Larger capacitors such as a 22µF or capacitors in parallel can be used if lower output voltage ripple is desired. To estimate the output voltage ripple considering the ripple due to capacitor discharge (ΔV_Q) and the ripple due to the capacitors ESR (ΔV_{ESR}) use the following equations:

For continuous conduction mode, the output voltage ripple due to the capacitor discharge is:

$$\Delta V_Q = \frac{I_{LED} \times (V_{OUT} - V_{IN})}{f_{SW} \times V_{OUT} \times C_{OUT}}$$

The output voltage ripple due to the output capacitors ESR is found by:

$$\Delta V_{ESR} = R_{ESR} \times \left(\frac{I_{LED} \times V_{OUT}}{V_{IN}} + \Delta I_L \right)$$

Where

$$\Delta I_L = \frac{V_{IN} \times (V_{OUT} - V_{IN})}{2 \times f_{SW} \times L \times V_{OUT}}$$

In ceramic capacitors the ESR is very low so the assumption is that 80% of the output voltage ripple is due to capacitor discharge and 20% from ESR.

Input Capacitor Selection

Choosing the correct size and type of input capacitor helps minimize the voltage ripple caused by the switching of the DIO5644 boost converter and reduce noise on the boost converter's input pin that can feed through and disrupt internal analog signals. In the typical application circuit a 10µF ceramic input capacitor works well. It is important to place the input capacitor as close as possible to the DIO5644 input (IN) pin. This reduces the series resistance and inductance that can inject noise into the device due to the input switching currents.

Inductor Selection

The DIO5644 is designed to use a 0.47µH or 1µH inductor. When the device is boosting ($V_{OUT} > V_{IN}$) the inductor is typically the largest area of efficiency loss in the circuit. Therefore, choosing an inductor with the lowest possible series resistance is important. Additionally, the saturation rating of the inductor should be

greater than the maximum operating peak current of the DIO5644. This prevents excess efficiency loss that can occur with inductors that operate in saturation. For proper inductor operation and circuit performance, ensure that the inductor saturation and the peak current limit setting of the DIO5644 are greater than I_{PEAK} in the following calculation:

$$I_{PEAK} = \frac{I_{LOAD}}{\eta} \times \frac{V_{OUT}}{V_{IN}} + \Delta I_L \quad \text{where} \quad \Delta I_L = \frac{V_{IN} \times (V_{OUT} - V_{IN})}{2 \times f_{SW} \times L \times V_{OUT}}$$

Where

$$f_{SW} = 2 \text{ or } 4 \text{ MHz}$$

Efficiency details can be found in the Application Curves.

Could choose inductor listed in the table below when $I_{LED}=1.5A$.

Recommend Power Inductor and Parameters

Manufacture	P/N	Inductance	DCR	Isat(A)		Irms(A)		Dimension
		uH	Ω	MAX	TPY	MAX	TPY	mm
Sunlord	WPN201610H1R0MT	1.0± 20%	0.075	3.35	3.85	2.05	2.35	2.0*1.6*1.0
Sunlord	WPN252010H1R0MT	1.0± 20%	0.076	3.10	3.50	2.50	2.90	2.5*2.0*1.0
Sunlord	WPN252012H1R0MT	1.0± 20%	0.054	3.60	4.20	3.00	3.40	2.5*2.0*1.2

Power Supply Recommendations

The DIO5644 is designed to operate from an input voltage supply range between 2.7V and 5.5V. This input supply must be well regulated and capable to supply the required input current. If the input supply is located far from the DIO5644 additional bulk capacitance may be required in addition to the ceramic bypass capacitors.

Layout Guidelines

The high switching frequency and large switching currents of the DIO5644 make the choice of layout very important. The following steps should be used for reference to ensure the device is stable and maintains proper LED current regulation across its intended operating voltage and current range.

1. Place C_{IN} on the top layer (same layer as the DIO5644) and as close to the device as possible. The input capacitor conducts the driver currents during the low-side MOSFET turn-on and turn-off and can detect current spikes over 1A in amplitude. Connecting the input capacitor through short, wide traces to both the IN and GND pins reduces the inductive voltage spikes that occur during switching which can corrupt the V_{IN} line.
2. Place C_{OUT} on the top layer (same layer as the DIO5644) and as close as possible to the OUT and GND pin. The returns for both C_{IN} and C_{OUT} should come together at one point, as close to the GND pin as possible. Connecting C_{OUT} through short, wide traces reduce the series inductance on the OUT and GND pins that can corrupt the V_{OUT} and GND lines and cause excessive noise in the device and surrounding circuitry.
3. Connect the inductor on the top layer close to the SW pin. There should be a low-impedance connection from the inductor to SW due to the large DC inductor current, and at the same time the area

occupied by the SW node should be small so as to reduce the capacitive coupling of the high dV/dT present at SW that can couple into nearby traces.

4. Avoid routing logic traces near the SW node so as to avoid any capacitive coupled voltages from SW onto any high-impedance logic lines such as TORCH/TEMP, STROBE, HWEN, SDA, and SCL. A good approach is to insert an inner layer GND plane underneath the SW node and between any nearby routed traces. This creates a shield from the electric field generated at SW.
5. Terminate the Flash LED cathodes directly to the GND pin of the DIO5644. If possible, route the LED returns with a dedicated path so as to keep the high amplitude LED currents out of the GND plane. For Flash LEDs that are routed relatively far away from the DIO5644, a good approach is to sandwich the forward and return current paths over the top of each other on two layers. This helps reduce the inductance of the LED current paths.

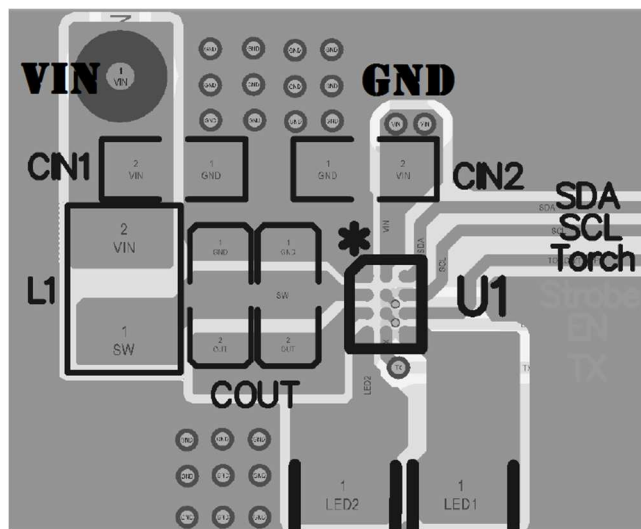

Figure 12. Layout Example

Typical Performance Characteristics

Ambient temperature is 25°C, input voltage is 3.6 V, $HWEN = V_{IN}$, $C_{IN} = C_{OUT} = 1 \times 10 \mu F$ and $L = 1 \mu H$, unless otherwise noted.

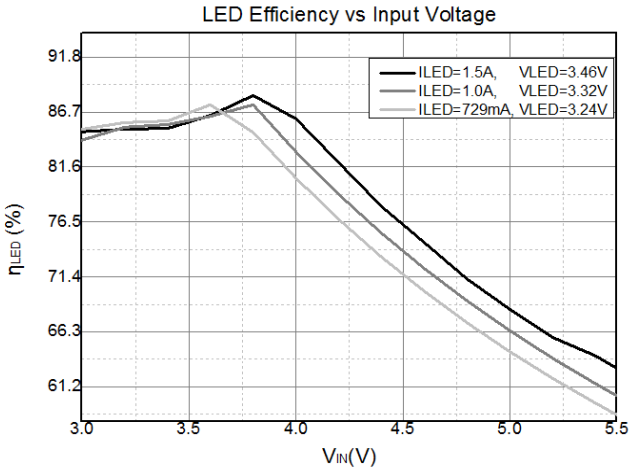

Figure 13. Flash Mode LED Efficiency

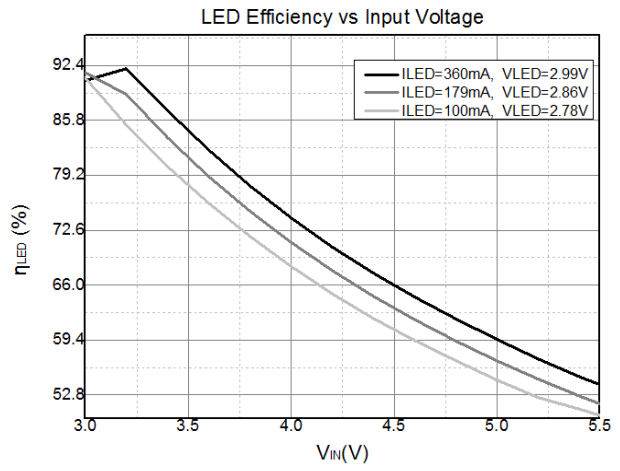

Figure 14. Torch Mode LED Efficiency

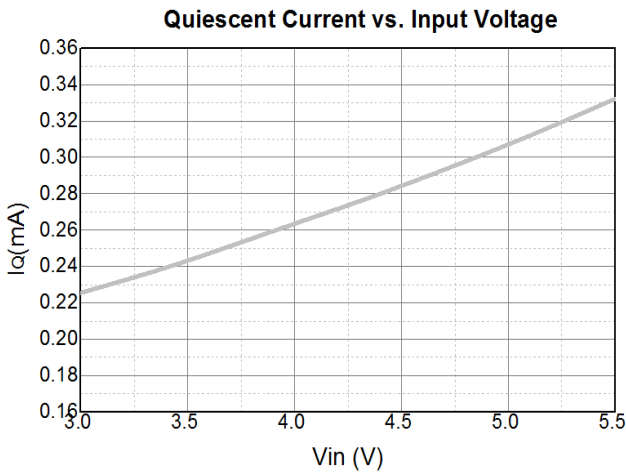

Figure 15. Quiescent Current vs. Input Voltage

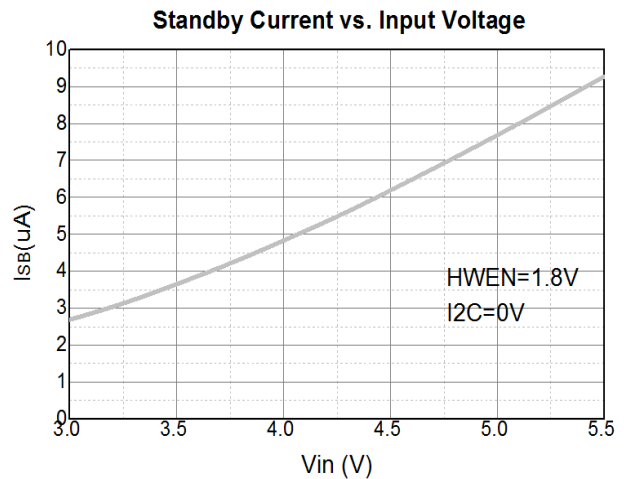

Figure 16. Standby Current vs. Input Voltage

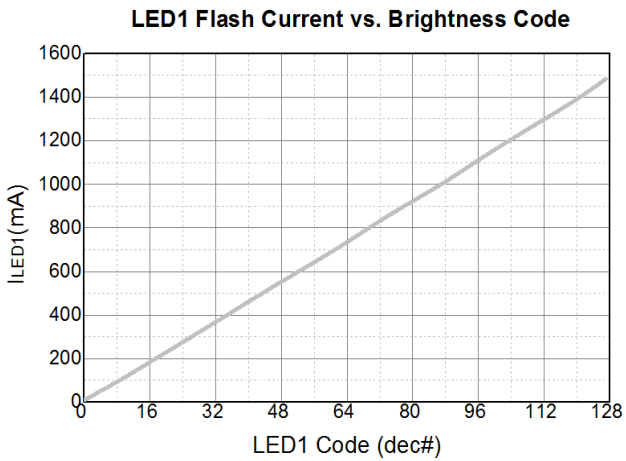

Figure 17. LED1 Flash Current vs Brightness Code

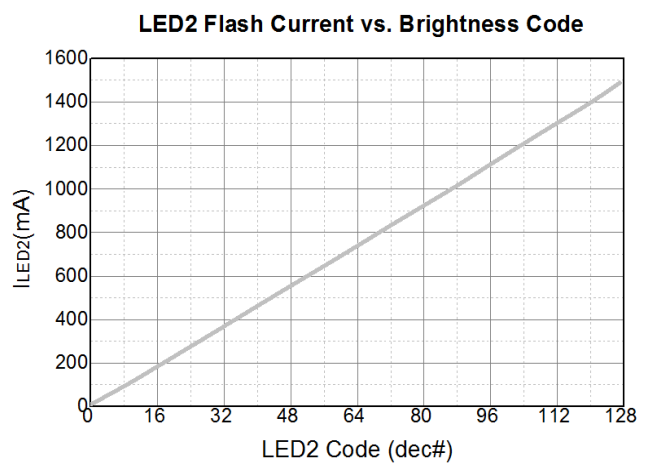

Figure 18. LED2 Flash Current vs Brightness Code

LED1 Torch Current vs. Brightness Code

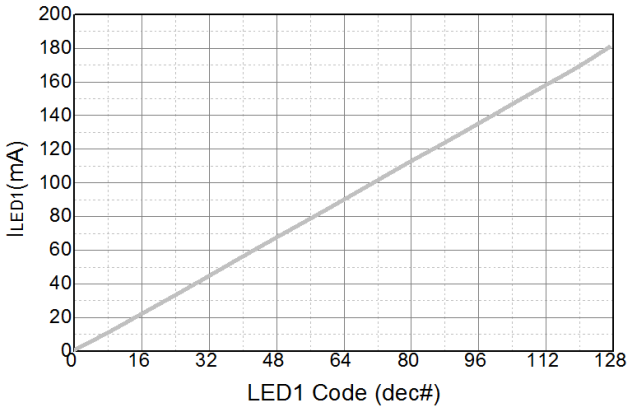

Figure 19. LED1 Torch Current vs Brightness Code

LED2 Torch Current vs. Brightness Code

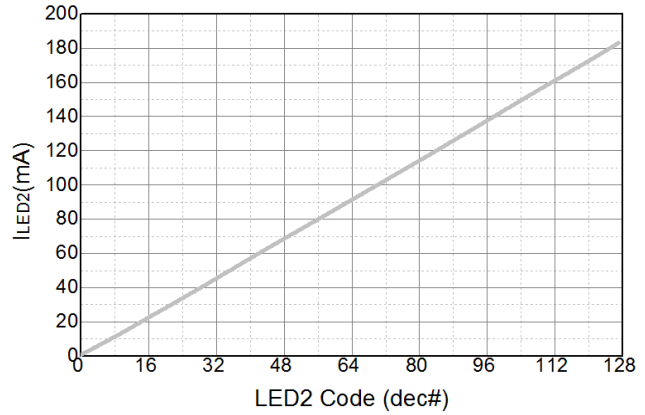

Figure 20. LED2 Torch Current vs Brightness Code

LED1 Torch Current x2 vs. Brightness Code

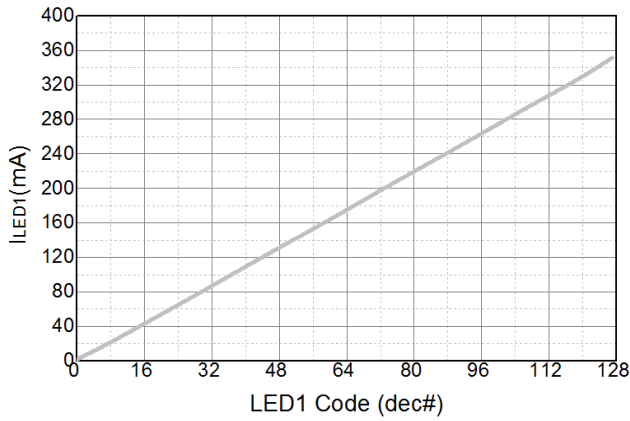

Figure 21. LED1 Torch Current x2 vs Brightness Code

LED2 Torch Current x2 vs. Brightness Code

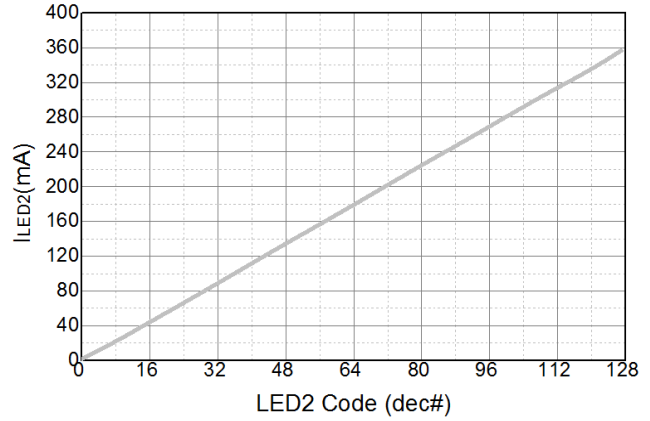

Figure 22. LED2 Torch Current x2 vs Brightness Code

LED Current vs. Input Voltage

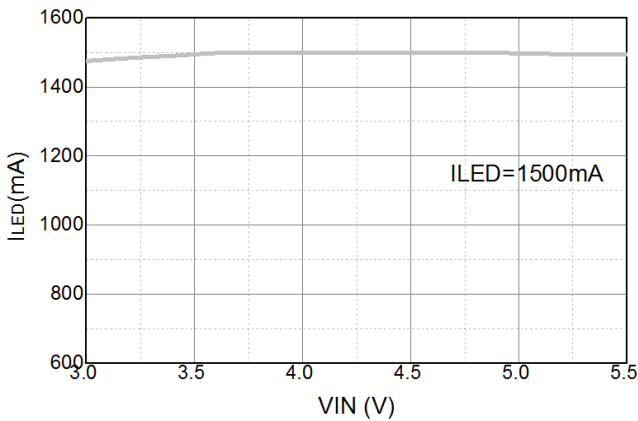

Figure 23. Flash Mode LED Current vs Input Voltage

LED Current vs. Input Voltage

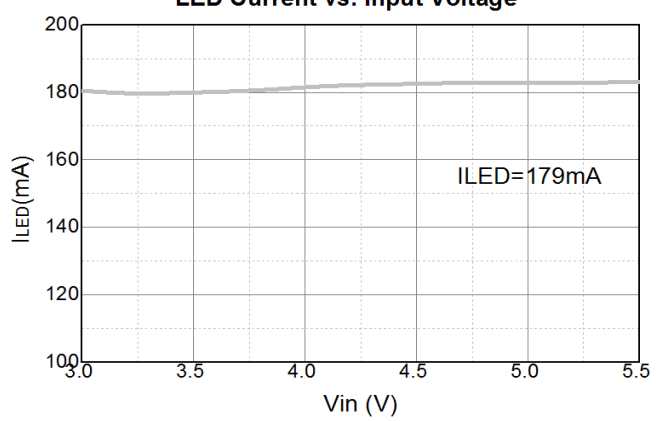
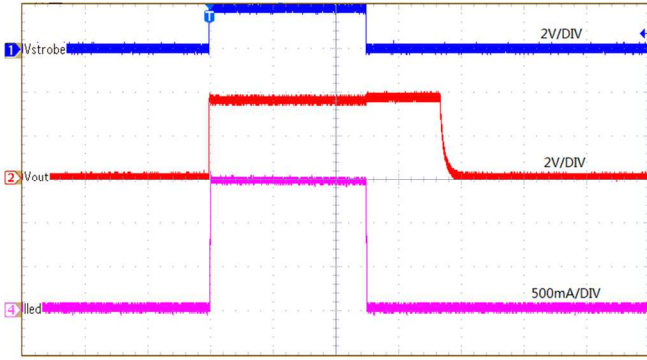
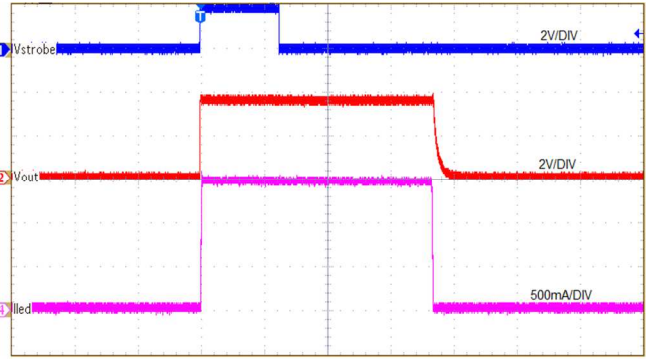

Figure 24. Torch Mode LED Current vs Input Voltage



Time (40ms/DIV)

Figure 25. Strobe pin Turn On Flash Mode(Level)



Time (40ms/DIV)

Figure 26. Strobe pin Turn On Flash Mode (Edge)

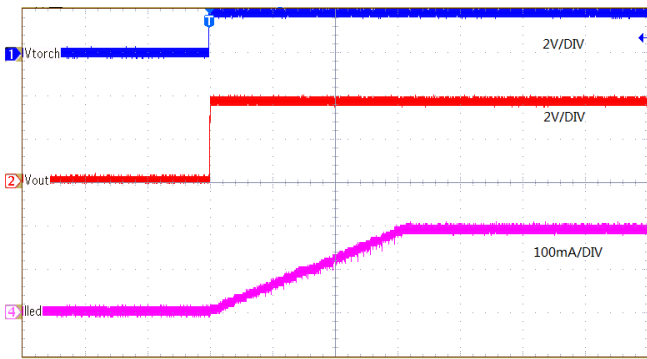

Time(10ms/DIV)

Figure 27. Torch pin Turn On Torch Mode (Ramp=32ms)

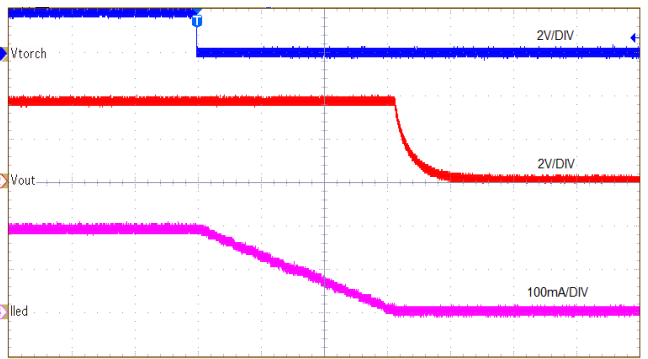

Time(10ms/DIV)

Figure 28. Torch pin Turn Off Torch Mode (Ramp=32ms)

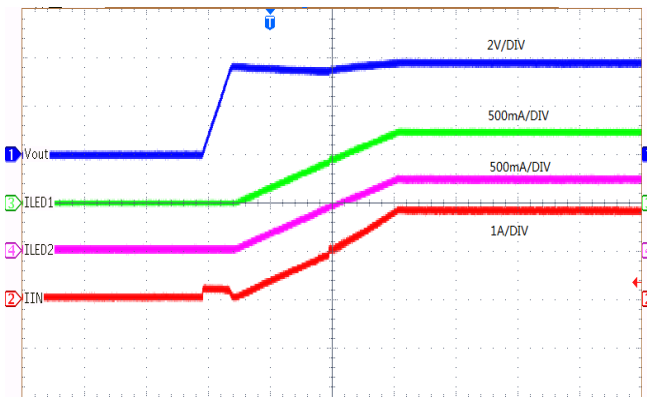

Time(400us/DIV)

Figure 29. Start-Up

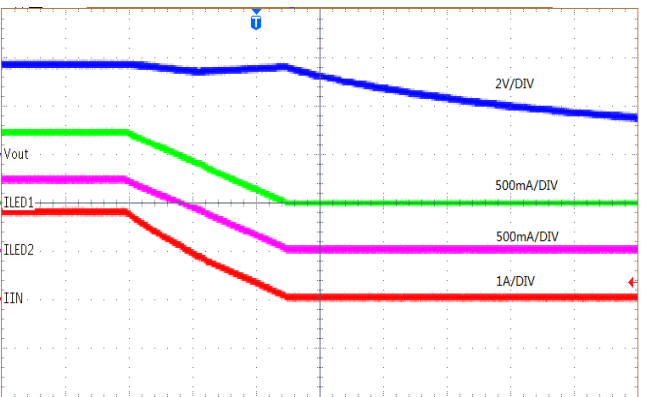

Time(400us/DIV)

Figure 30. Ramp Down

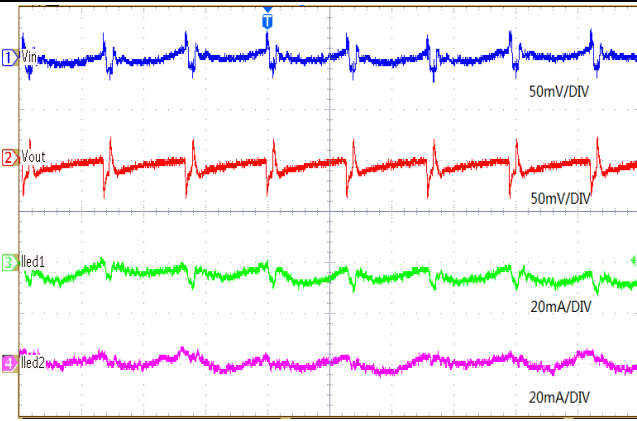

Time (400ns/DIV)

Figure 31. Ripple @ 2 MHz

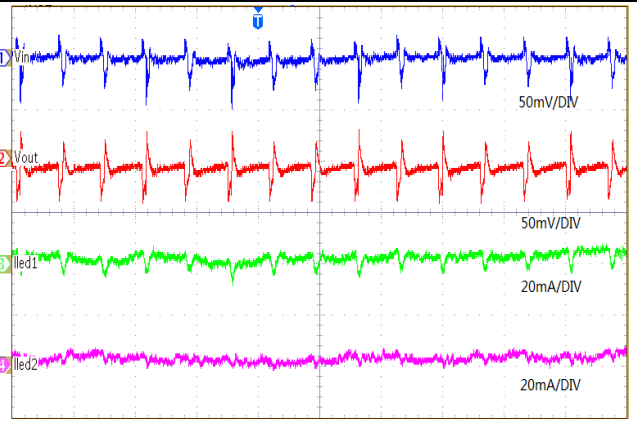

Time (400ns/DIV)

Figure 32. Ripple @ 4 MHz

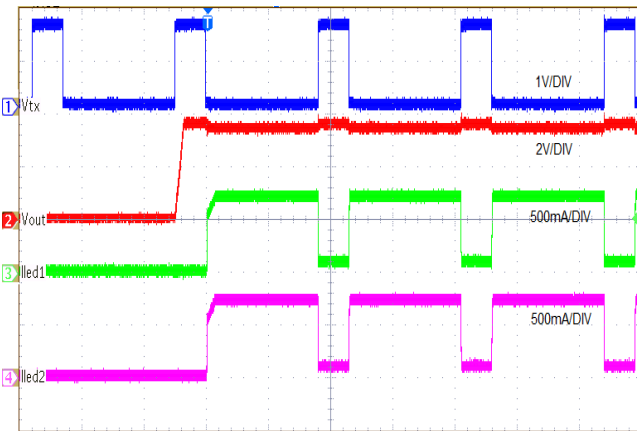

Time (2ms/DIV)

Figure 33. TX Function

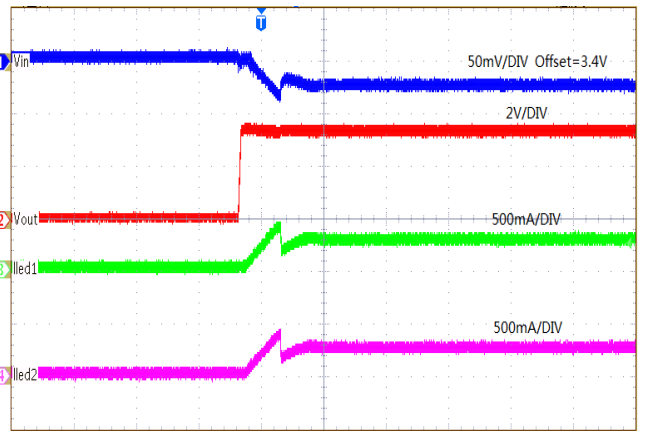

Time (1ms/DIV)

Figure 34. IVFM down mode



DIO5644

CONTACT US

Dioo is a professional design and sales corporation for high-quality and performance analog semiconductors. The company focuses on industry markets, such as, cell phone, handheld products, laptop, and medical equipment and so on. Dioo's product families include analog signal processing and amplifying, LED drivers and charger IC. Go to <http://www.dioo.com> for a complete list of Dioo product families.

For additional product information, or full datasheet, please contact with our Sales Department or Representatives.